



**OVENSULJIN
DÖRRSTÄNGARE
DOOR CLOSER
UKSESULGUR
DURVJU AIZVĒRĒJS
DURŲ UŽDARYMO ĮTAISAS**

Käyttö- ja kasausohje
Monterings- och bruksanvisning
Assembly and use
Kokkupanek ja kasutamine
Surinkimas ir naudojimas
Montāža un lietošana



Art.nr. 10301870

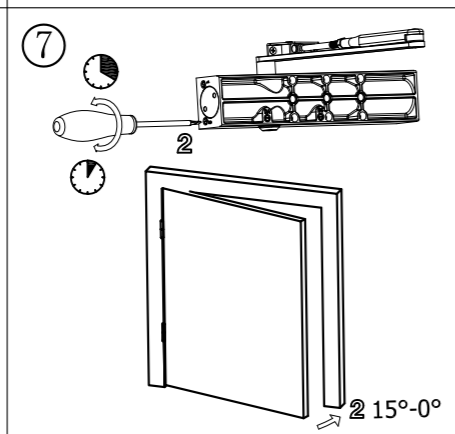
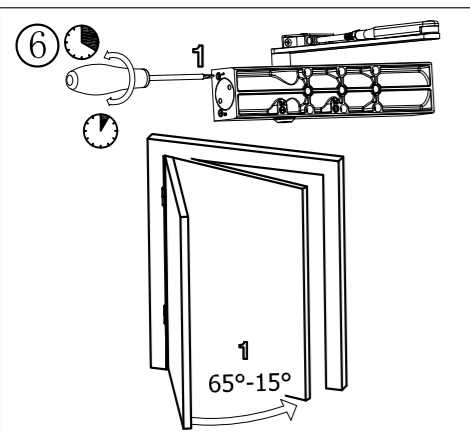
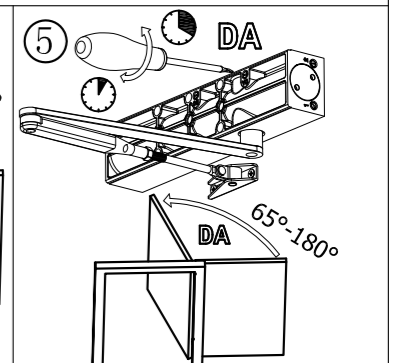
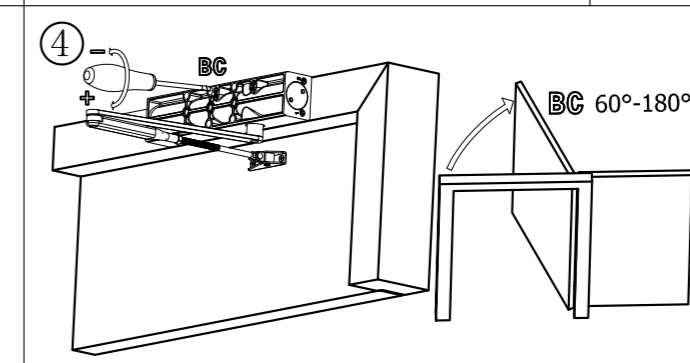
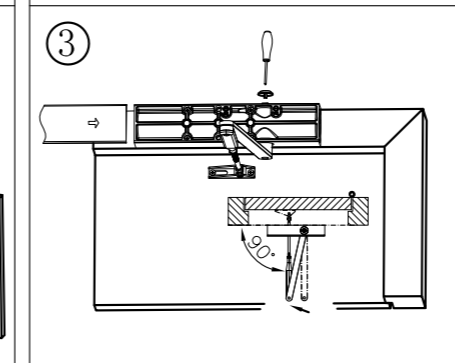
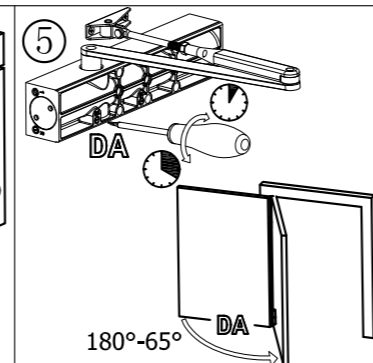
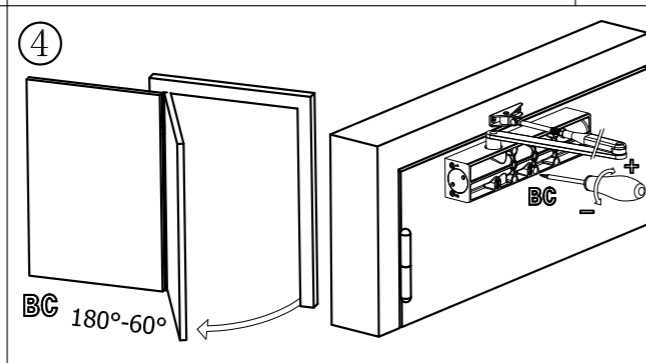
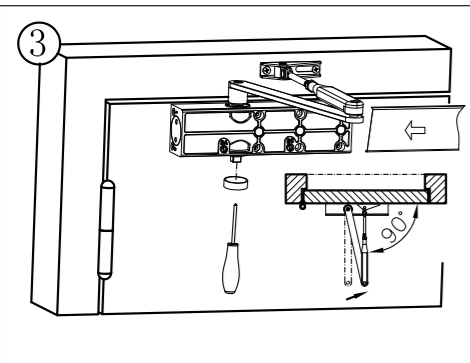
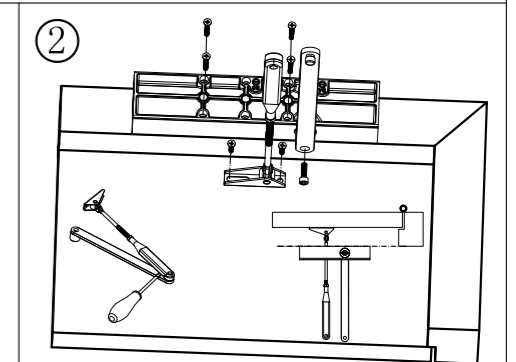
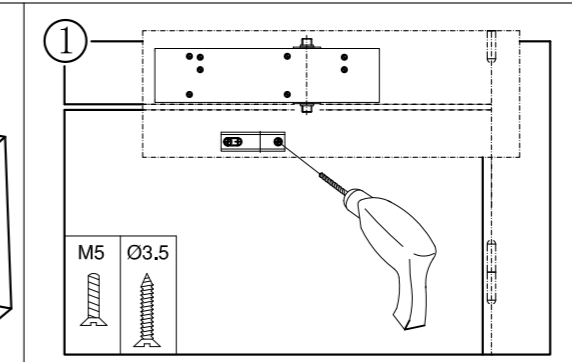
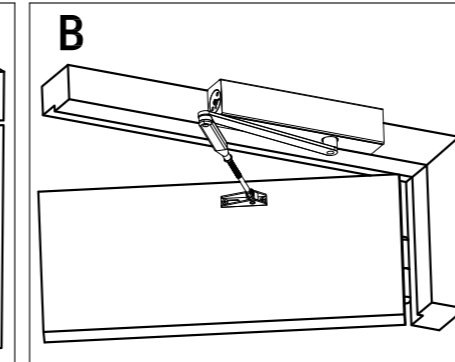
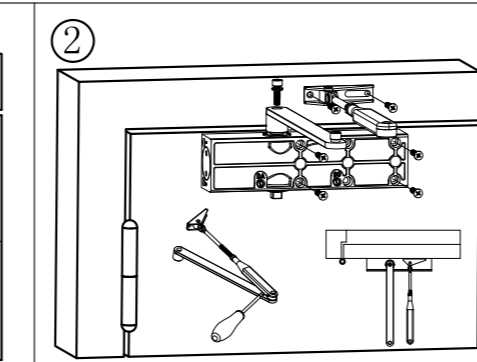
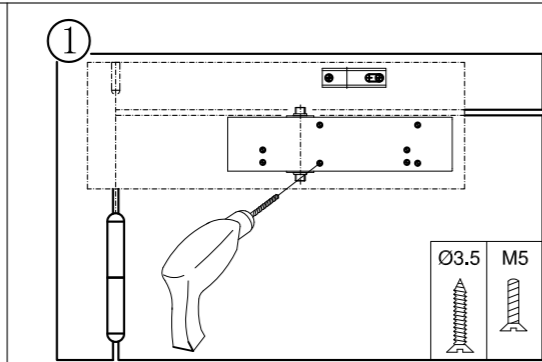
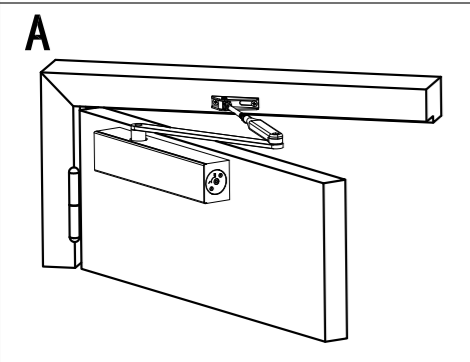
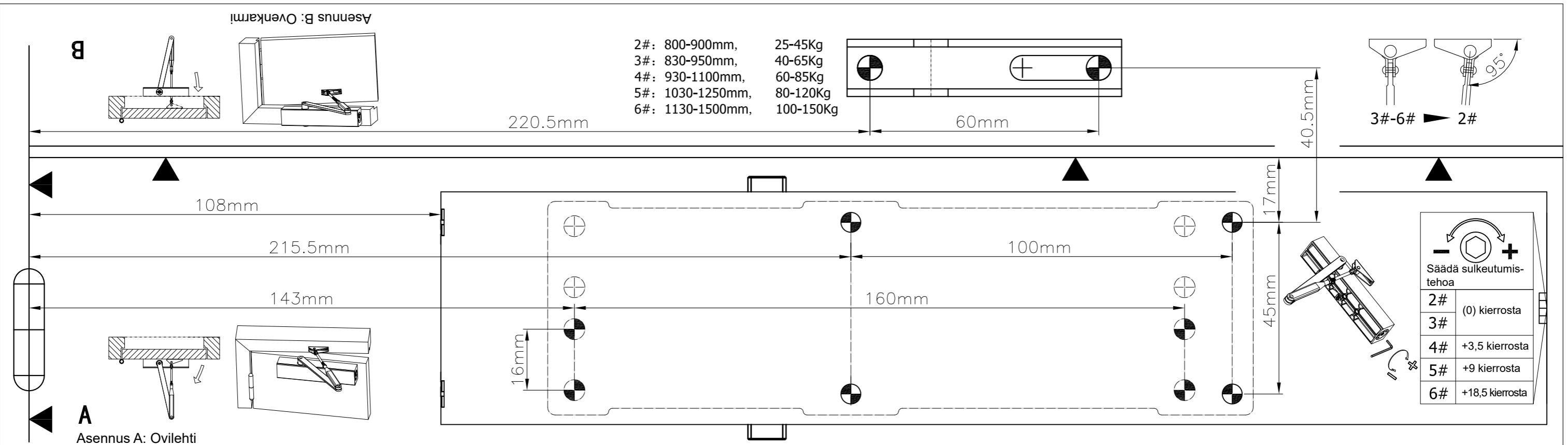

Varoitus

1. Älä käännä ovensulkimen neliökantaa yli 180 astetta ennen asennusta, muuten ovensuljin vaurioituu.
2. Kun asennat ovensulkimen vetolaitteen neliökantaan, älä iske sitä voimakkaasti, muuten ovensuljin vaurioituu.
3. Ovensulkimessa on automaattinen sulkeutumistoiminto. Älä käytä ulkoista voimaa oven sulkemiseen, muuten ovensuljin vaurioituu.
4. Laitteen oltua käytössä kuukauden tarkista, etteivät eri osien ruuvit ole löystyneet.
5. Huomioi kesä- ja talvikausien väliset lämpötilaerot, kun säädät sulkemisnopeutta.
6. Kun säädät nopeutta, älä kierrä nopeudensäätöventtiilin ruuvia rungon pintaa korkeammalle, muuten öljy voi vuotaa.

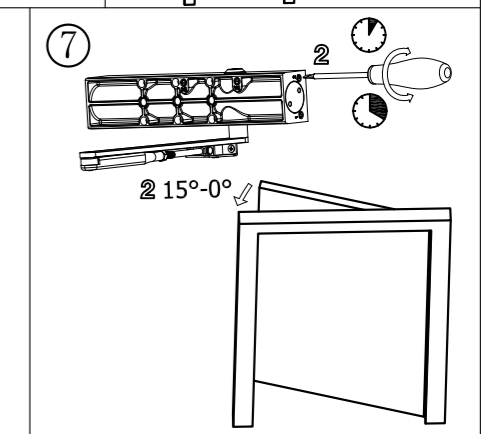
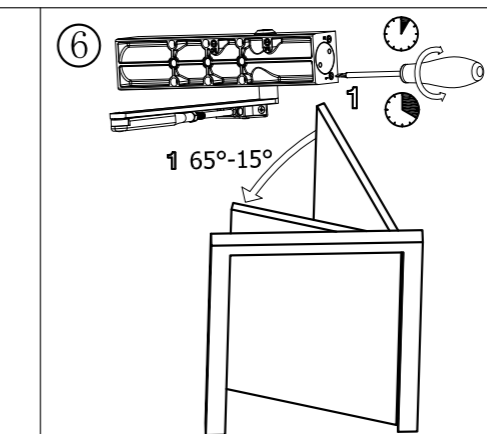

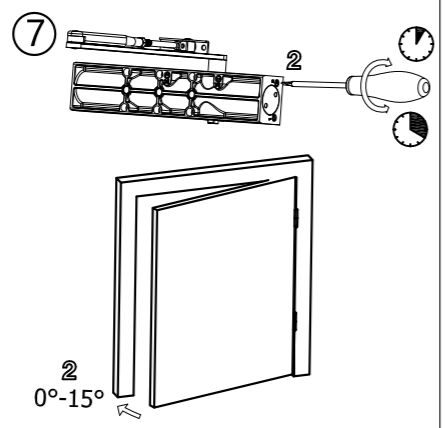
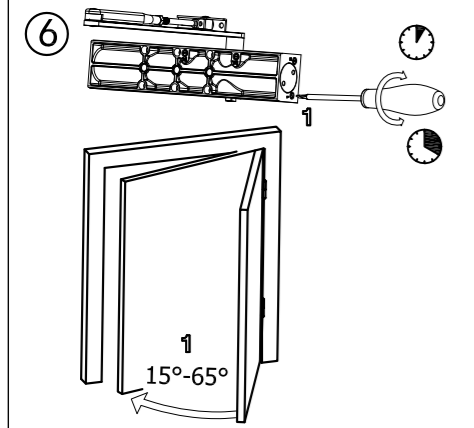
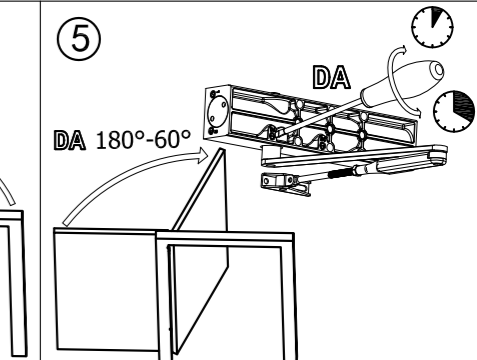
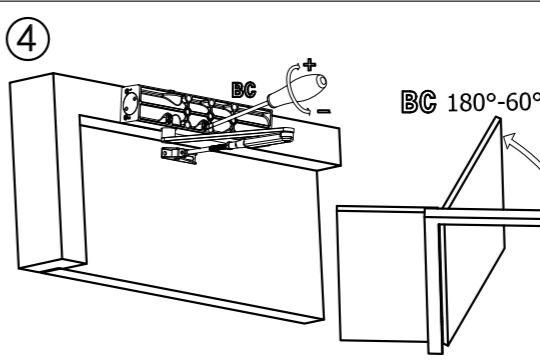
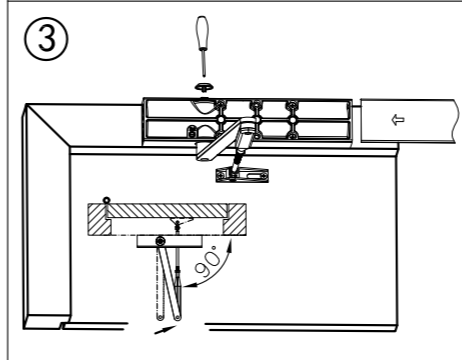
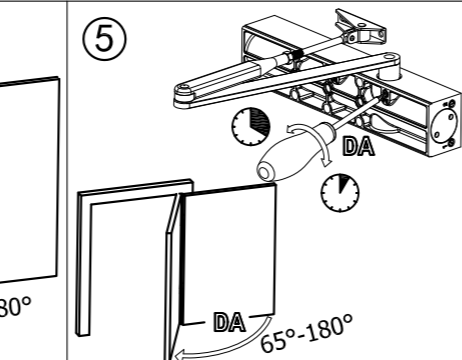
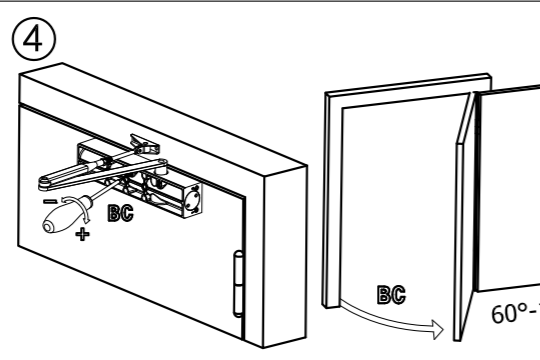
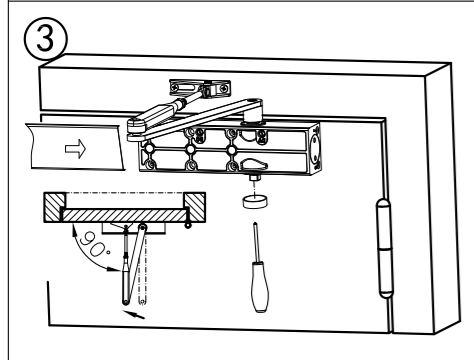
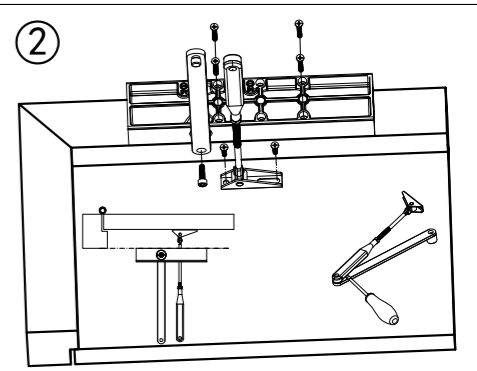
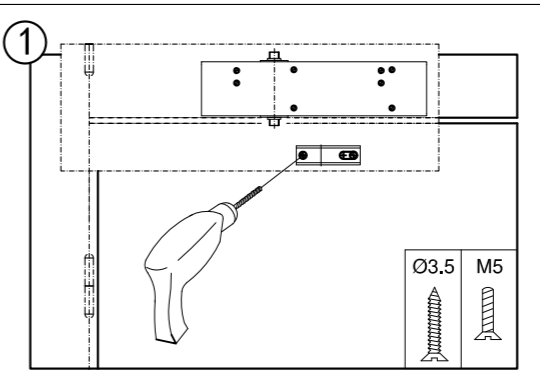
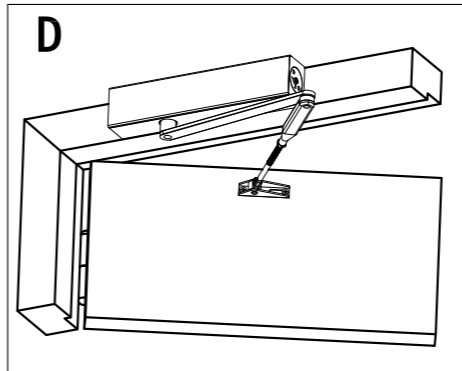
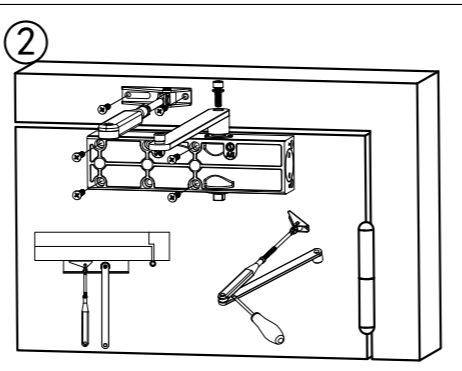
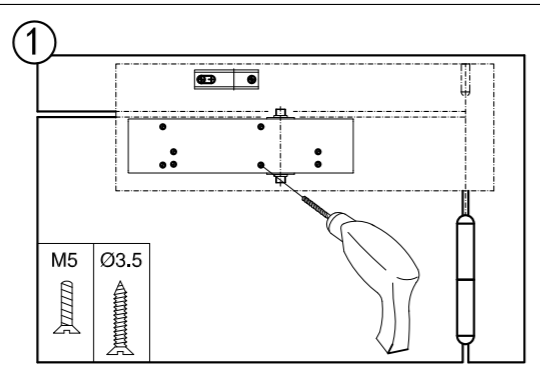
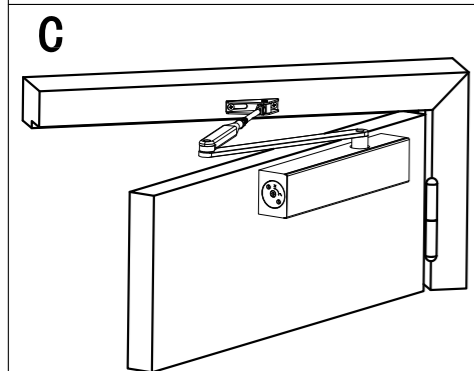
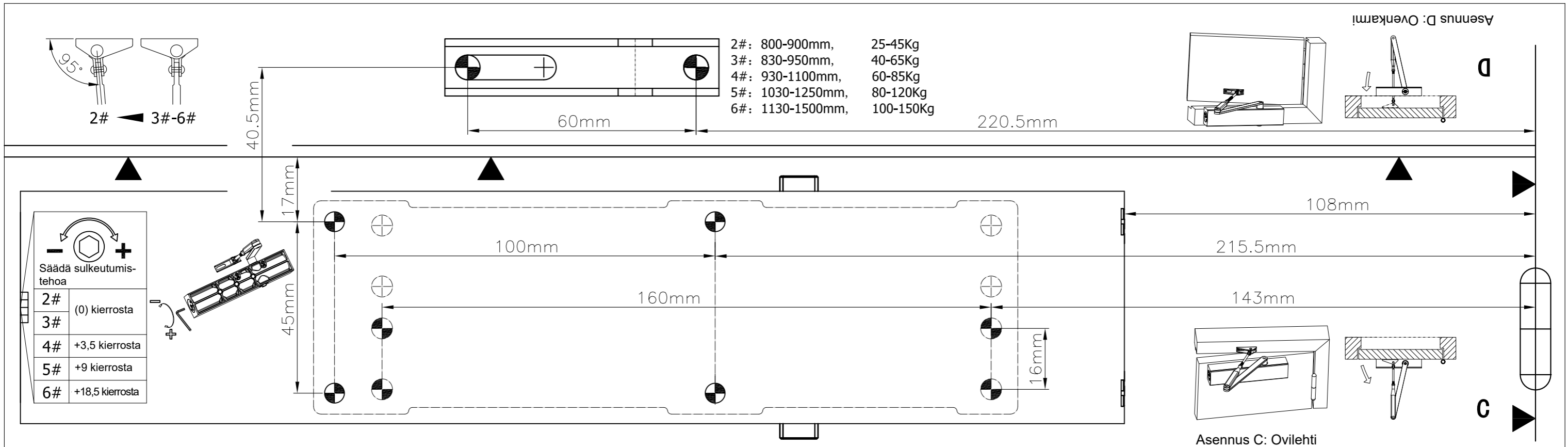

Varoitus

1. Älä käännä ovensulkimen neliökantaa yli 180 astetta ennen asennusta, muuten ovensuljin vaurioituu.
2. Kun asennat ovensulkimen vetolaitteen neliökantaan, älä iske sitä voimakkaasti, muuten ovensuljin vaurioituu.
3. Ovensulkimessa on automaattinen sulkeutumistoiminto. Älä käytä ulkoista voimaa oven sulkemiseen, muuten ovensuljin vaurioituu.
4. Laitteen oltua käytössä kuukauden tarkista, etteivät eri osien ruuvit ole löystyneet.
5. Huomioi kesä- ja talvikausien väliset lämpötilaerot, kun säädät sulkemisnopeutta.
6. Kun säädät nopeutta, älä kierrä nopeudensäätöventtiin ruuvia rungon pintaa korkeammalle, muuten öljy voi vuotaa.

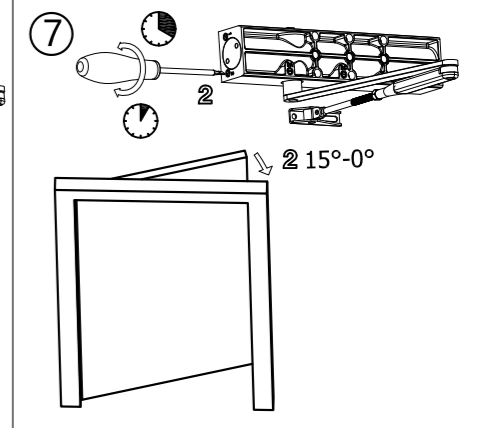
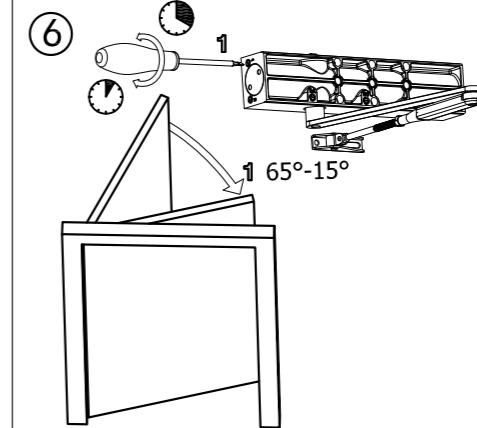

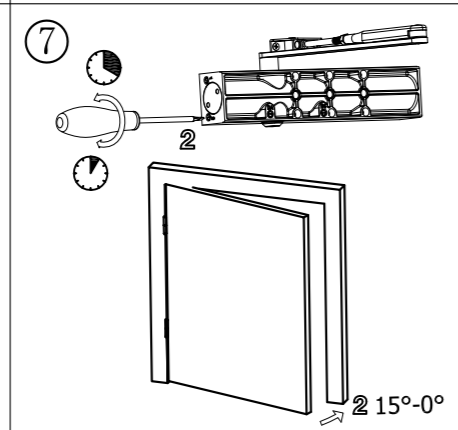
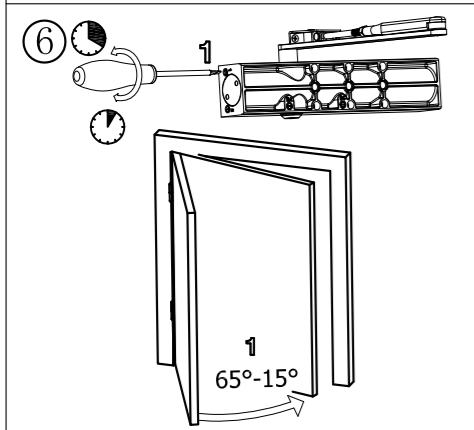
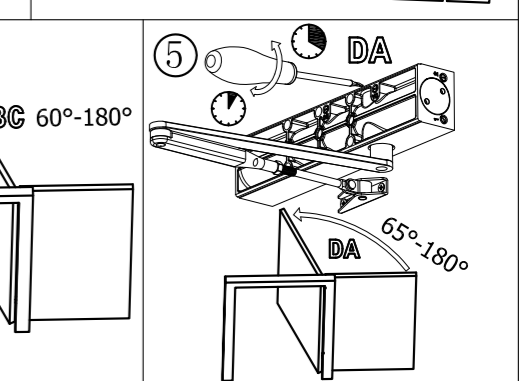
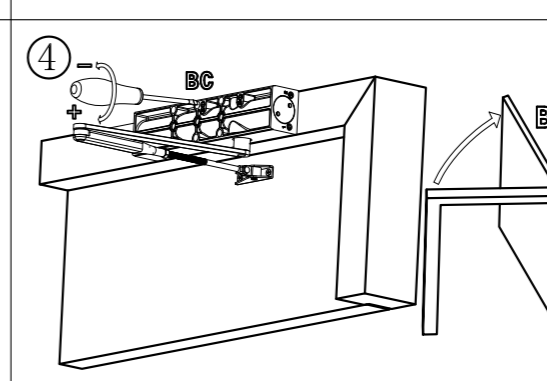
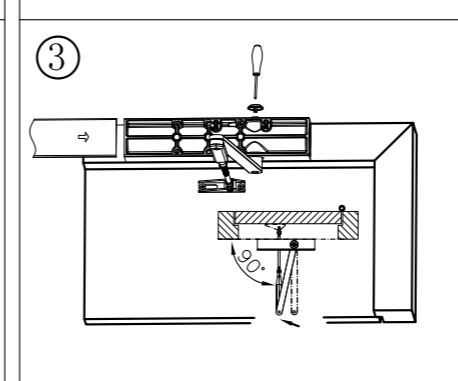
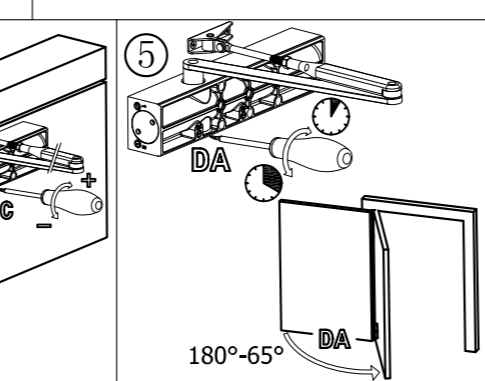
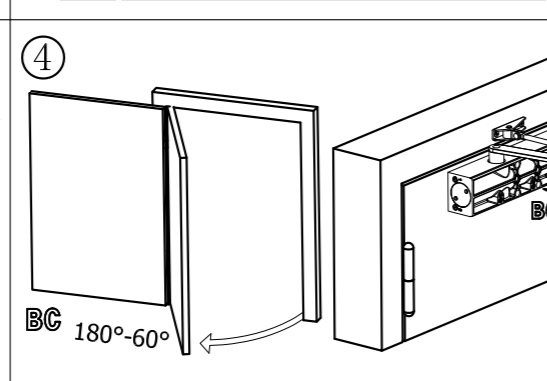
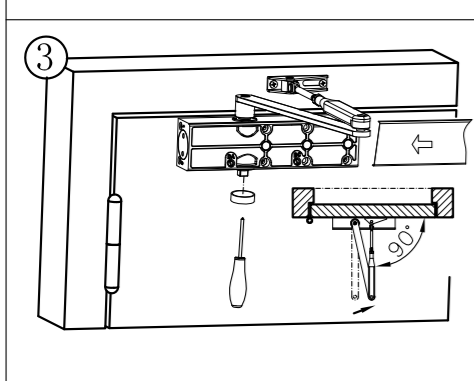
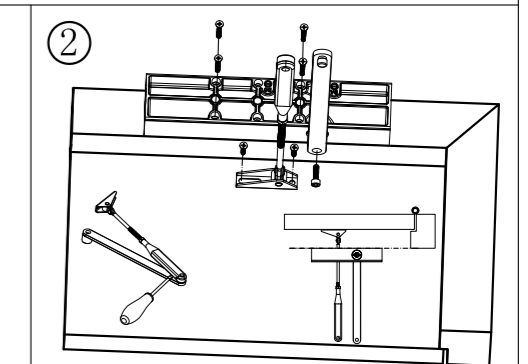
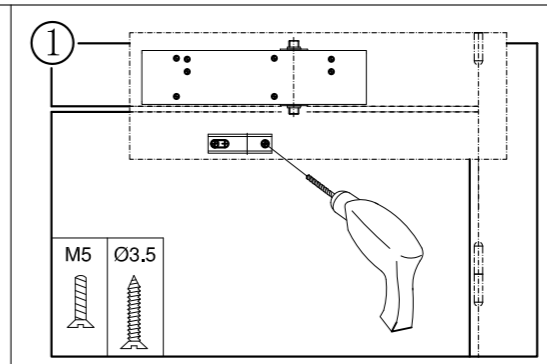
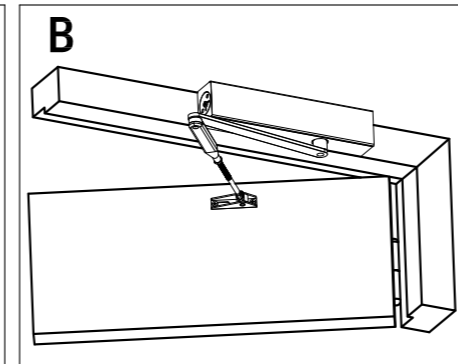
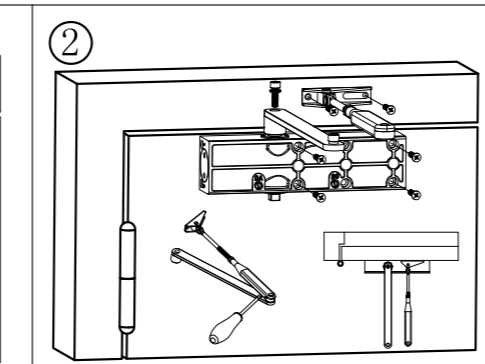
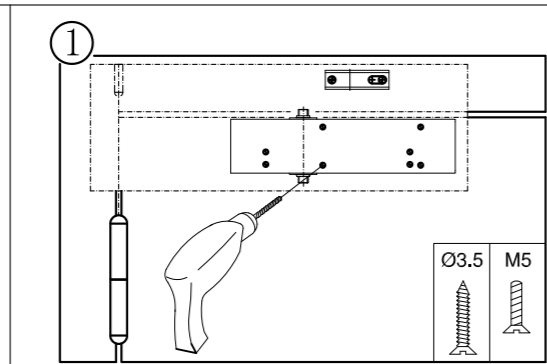
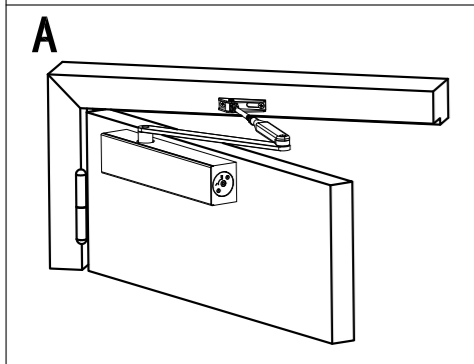
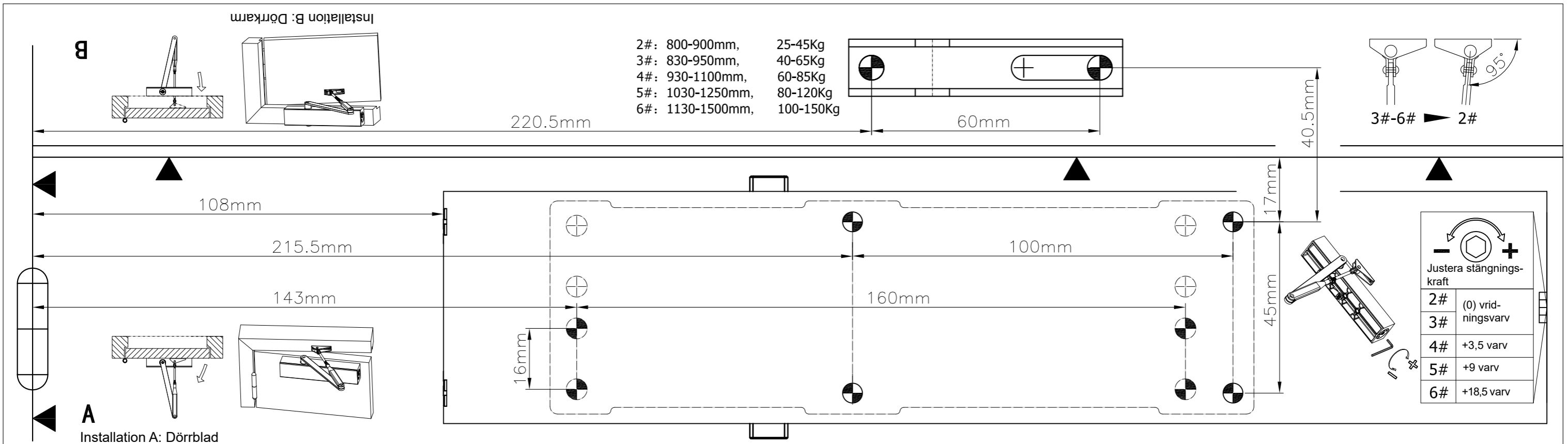

Var försiktig

- Innan dörrstängaren installeras är det strängt förbjudet att vrida fyrkantshuvudet på dörrstängaren mer än 180 grader, det kan göra att dörrstängaren skadas.
- När dörrstängarens länkkarm är installerad på fyrkantshuvudet är det strängt förbjudet att hamra hårt på den, det kan göra att dörrstängaren skadas.
- Dörrstängaren har en automatisk dörrstängningsfunktion. Det är strängt förbjudet att tvinga dörren att stängas av en yttre kraft, det kan göra att dörrstängaren skadas.
- En månad efter första installation och användning, kontrollera skruvarna i varje del så att de inte är lösa.
- På grund av temperaturskillnaderna mellan sommar- och vintersäsonger ska man vara uppmärksam på att justera stängningshastigheten.
- Vid justering av hastigheten är det strängt förbjudet att vrida hastighetsregleringsventilens skruv högre än höljets yta, det kan att orsaka oljeläckage.

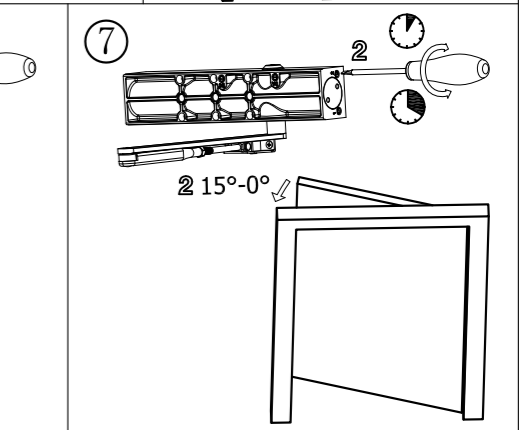
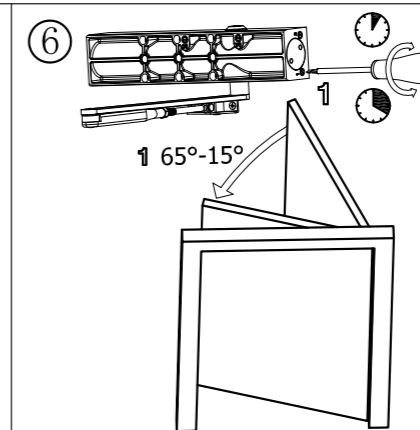

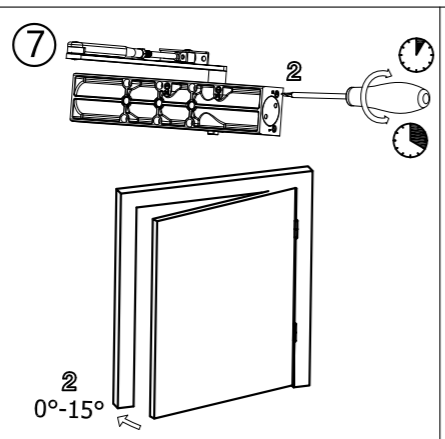
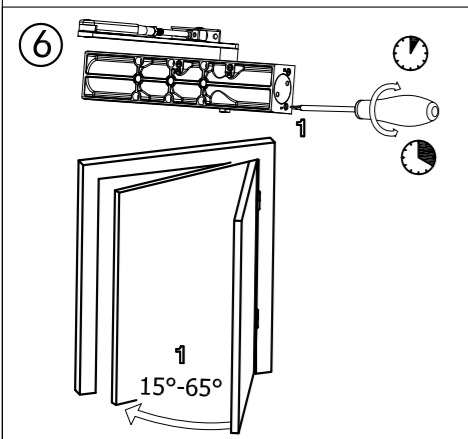
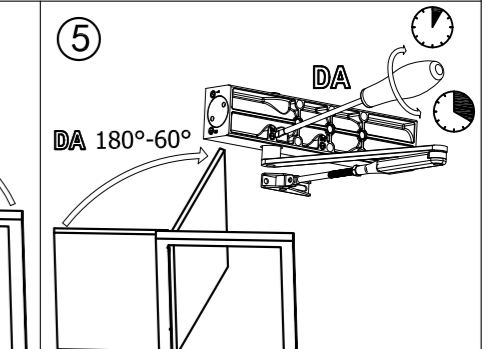
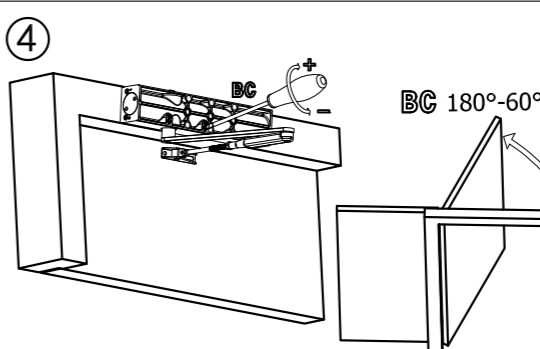
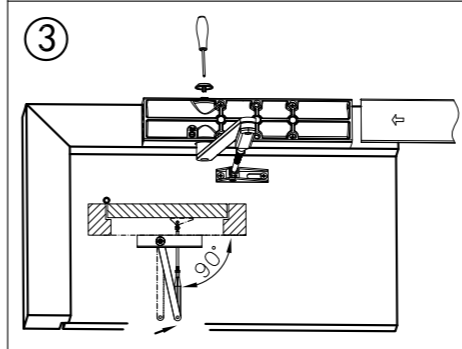
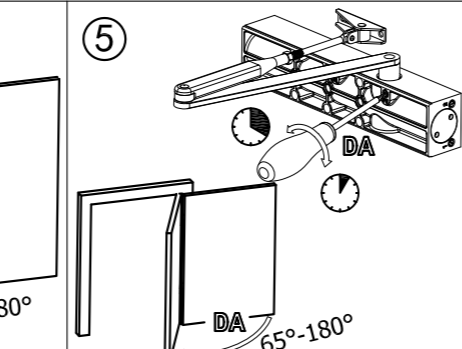
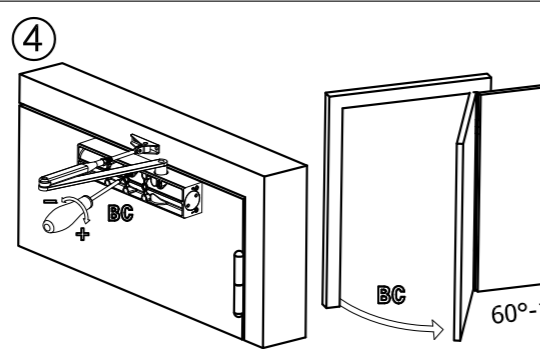
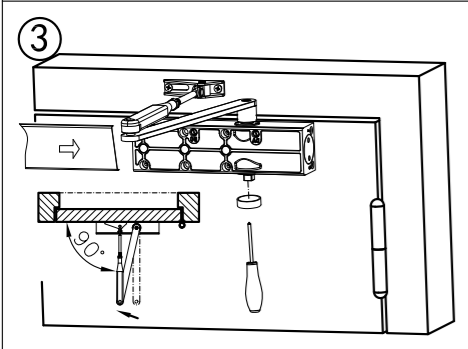
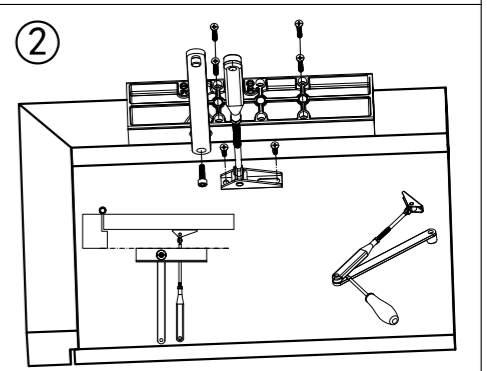
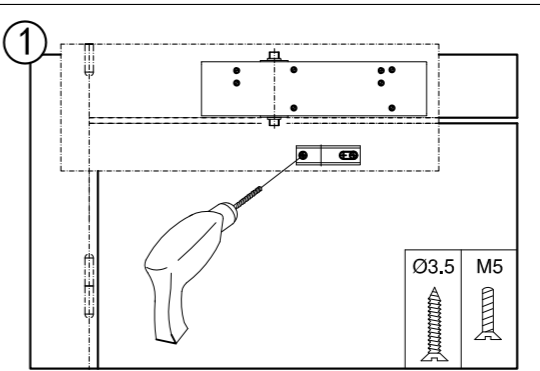
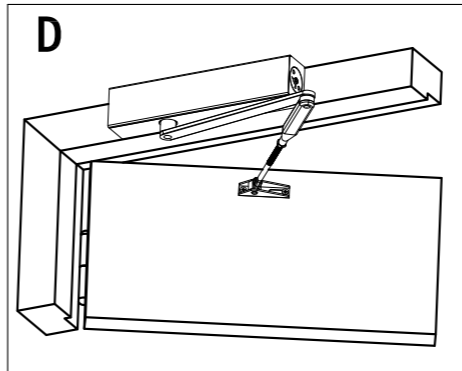
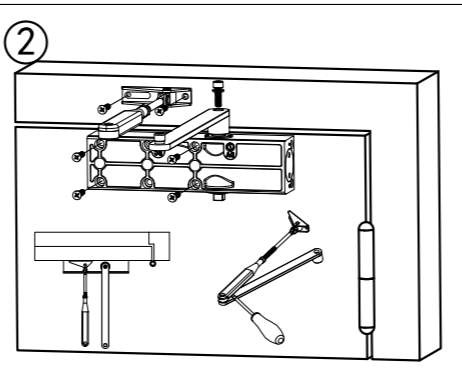
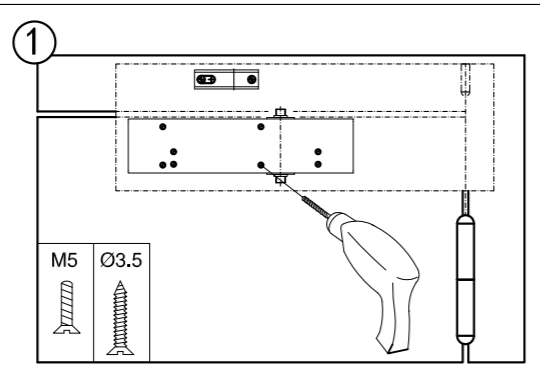
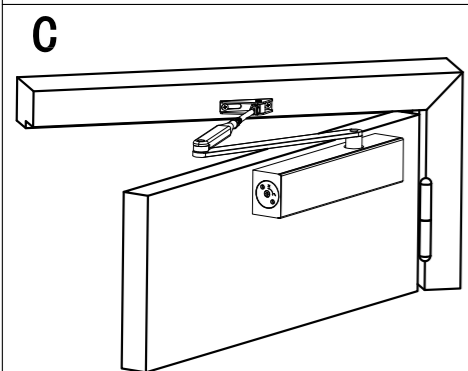
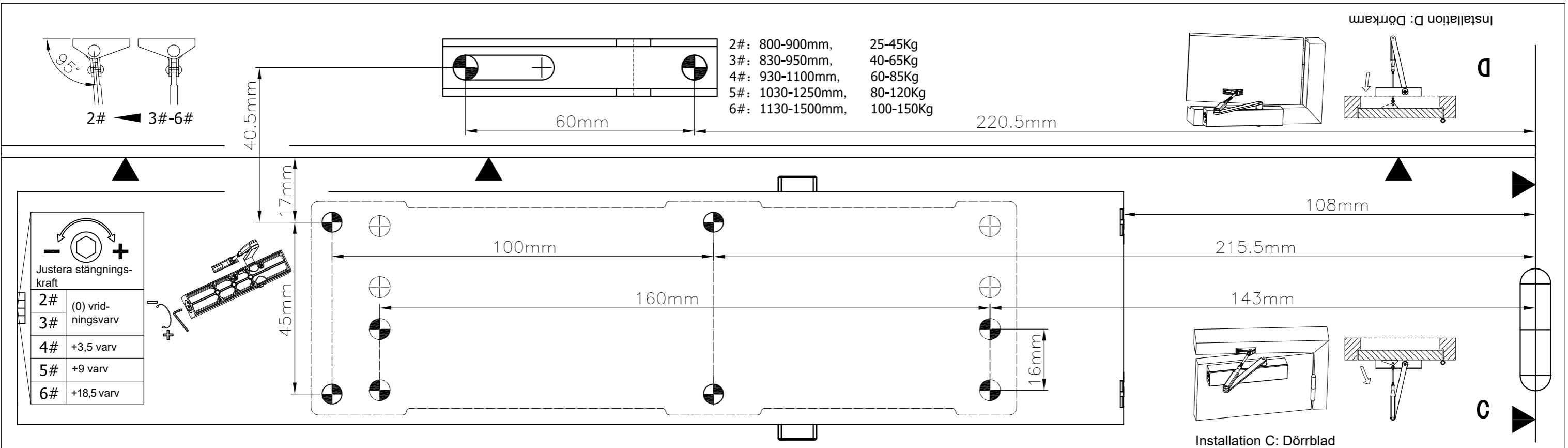

Var försiktig

- Innan dörrstängaren installeras är det strängt förbjudet att vrida fyrkantshuvudet på dörrstängaren mer än 180 grader, det kan göra att dörrstängaren skadas.
- När dörrstängarens länkkarm är installerad på fyrkantshuvudet är det strängt förbjudet att hamra hårt på den, det kan göra att dörrstängaren skadas.
- Dörrstängaren har en automatisk dörrstängningsfunktion. Det är strängt förbjudet att tvinga dörren att stängas av en yttre kraft, det kan göra att dörrstängaren skadas.
- En månad efter första installation och användning, kontrollera skruvarna i varje del så att de inte är lösa.
- På grund av temperaturskillnaderna mellan sommar- och vintersäsonger ska man vara uppmärksam på att justera stängningshastigheten.
- Vid justering av hastigheten är det strängt förbjudet att vrida hastighetsregleringsventilens skruv högre än höljets yta, det kan att orsaka oljeläckage.

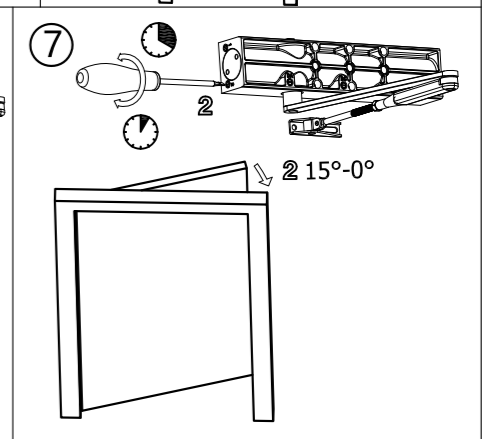
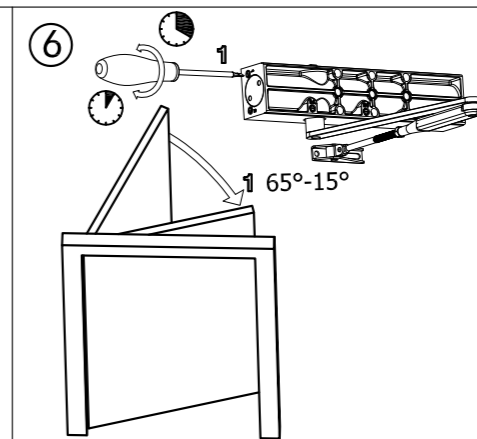

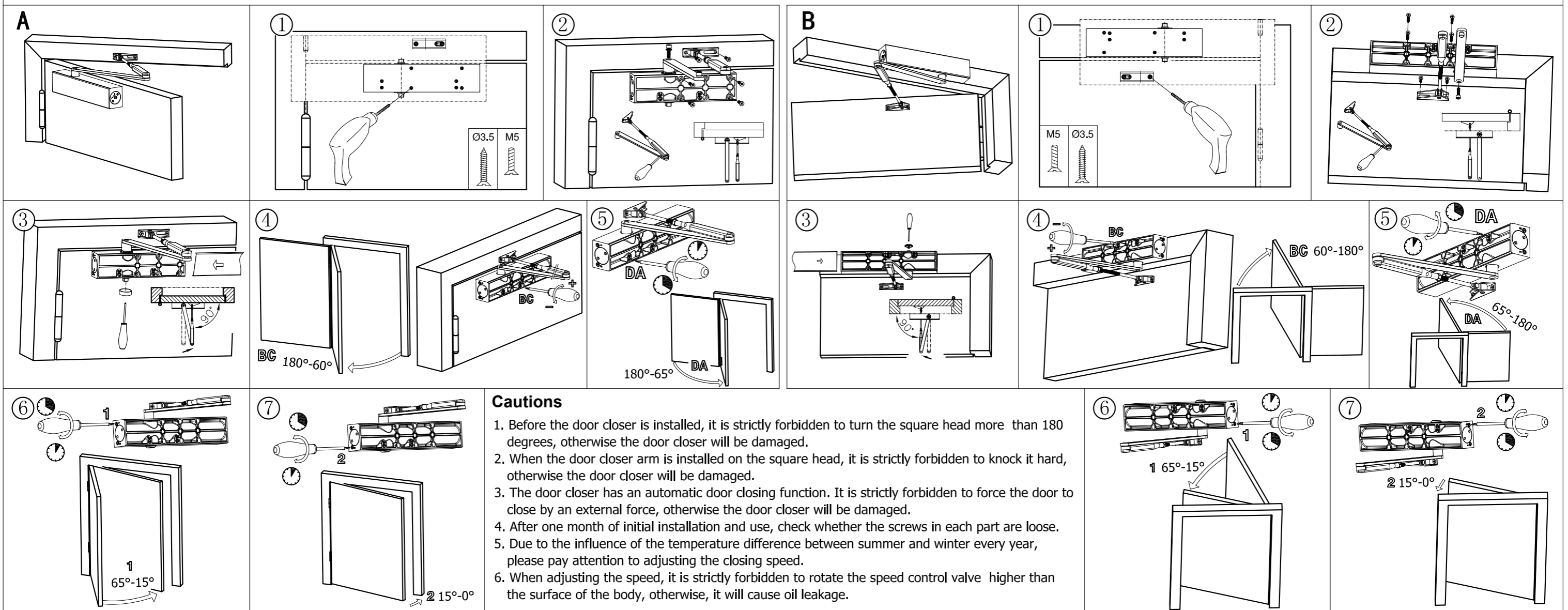
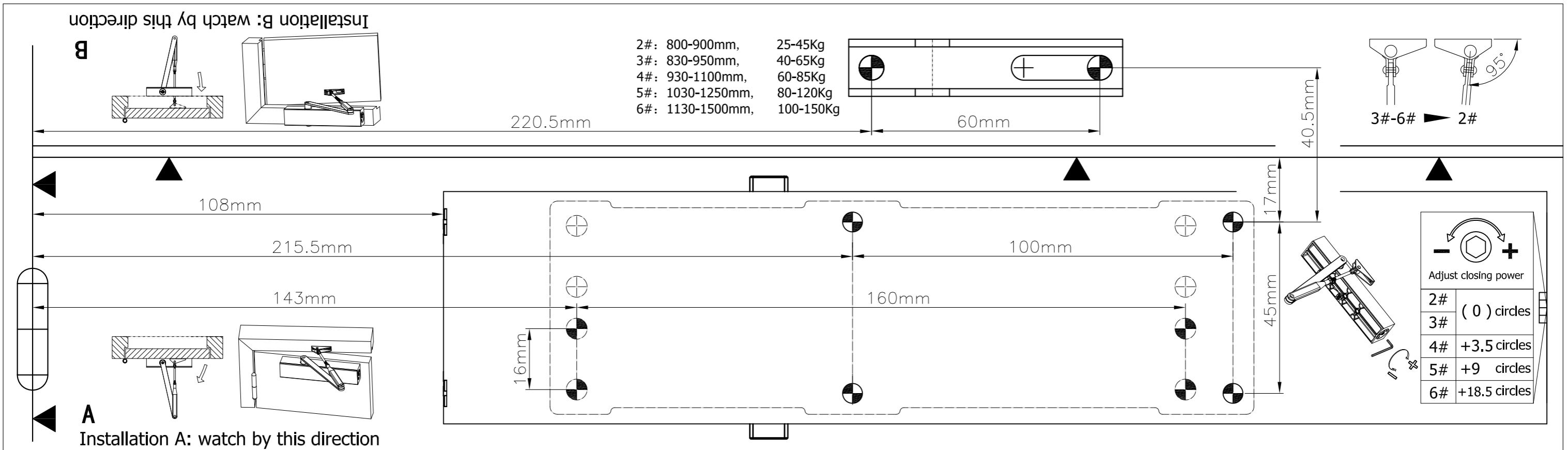

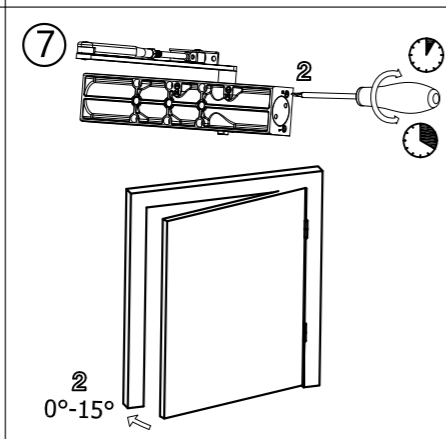
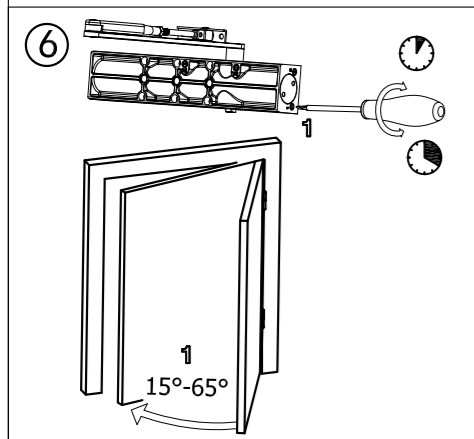
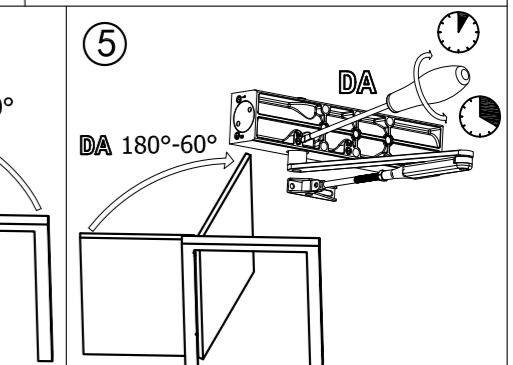
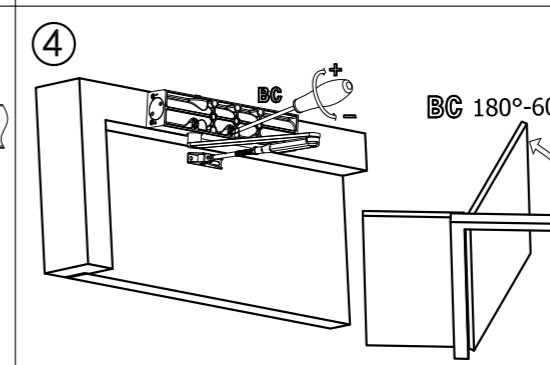
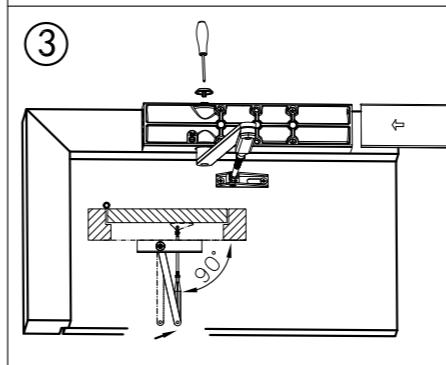
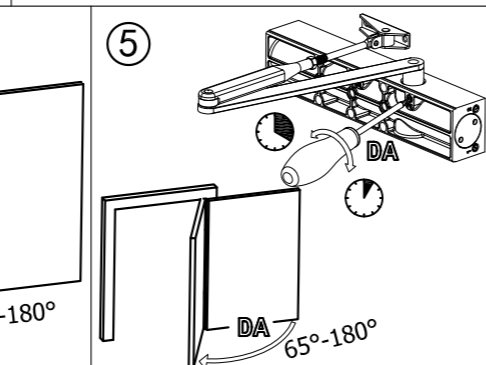
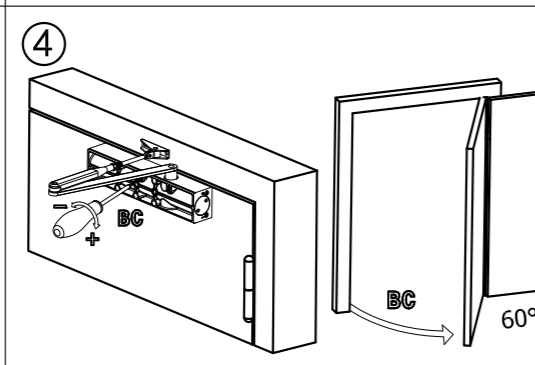
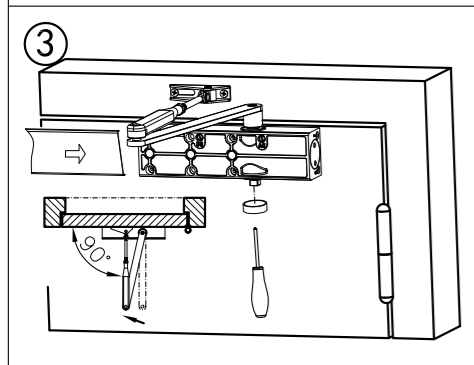
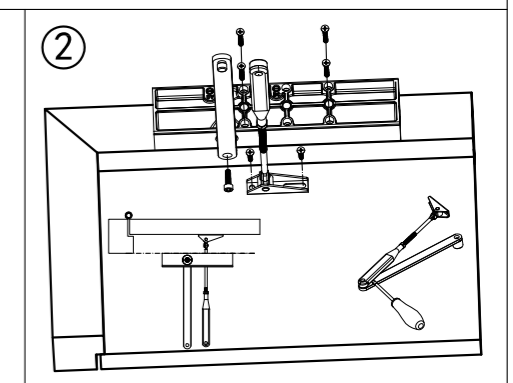
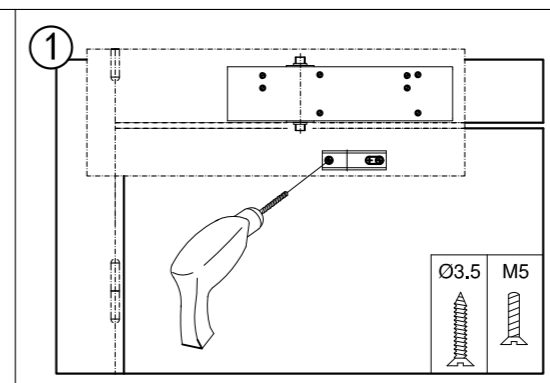
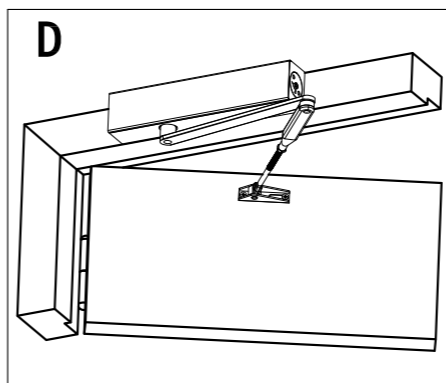
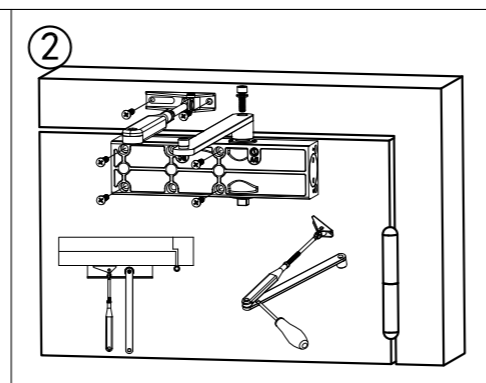
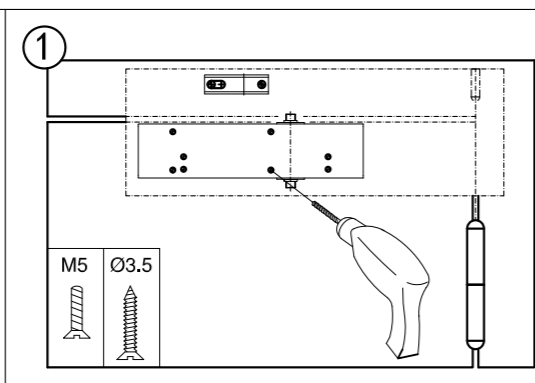
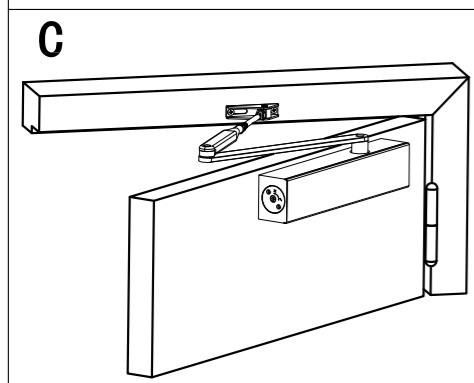
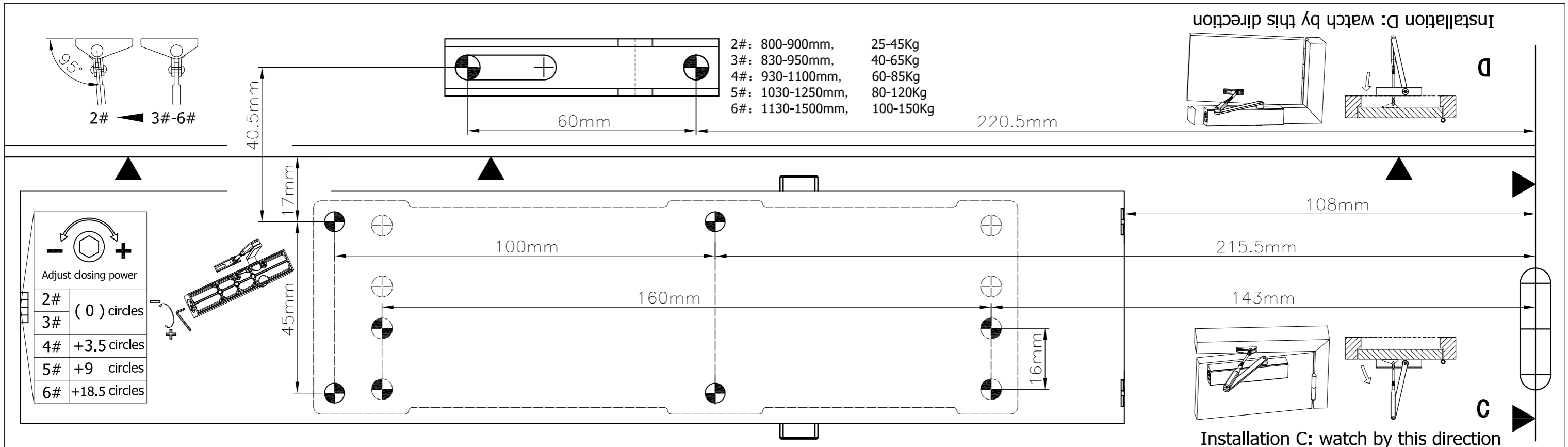

Cautions

1. Before the door closer is installed, it is strictly forbidden to turn the square head more than 180 degrees, otherwise the door closer will be damaged.
2. When the door closer arm is installed on the square head, it is strictly forbidden to knock it hard, otherwise the door closer will be damaged.
3. The door closer has an automatic door closing function. It is strictly forbidden to force the door to close by an external force, otherwise the door closer will be damaged.
4. After one month of initial installation and use, check whether the screws in each part are loose.
5. Due to the influence of the temperature difference between summer and winter every year, please pay attention to adjusting the closing speed.
6. When adjusting the speed, it is strictly forbidden to rotate the speed control valve higher than the surface of the body, otherwise, it will cause oil leakage.

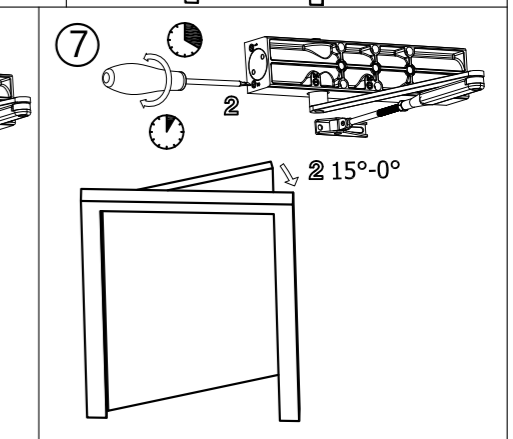
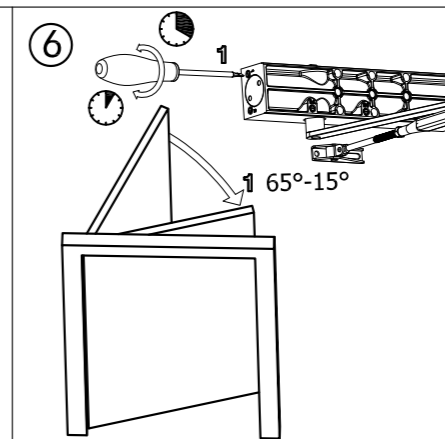

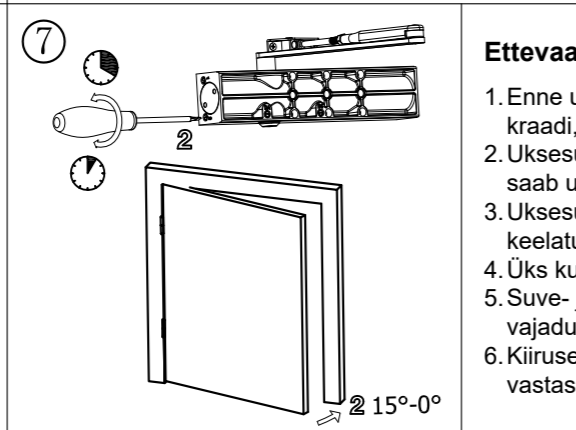
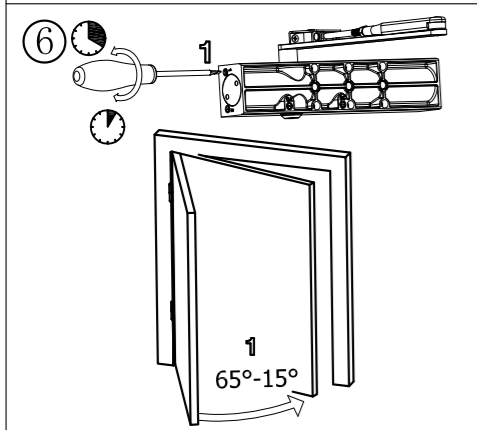
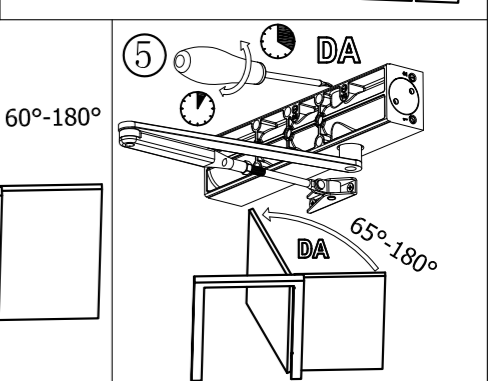
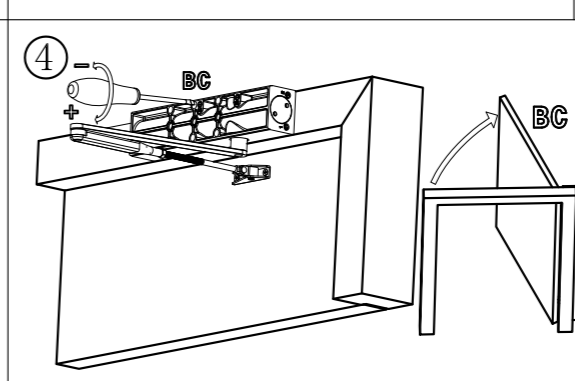
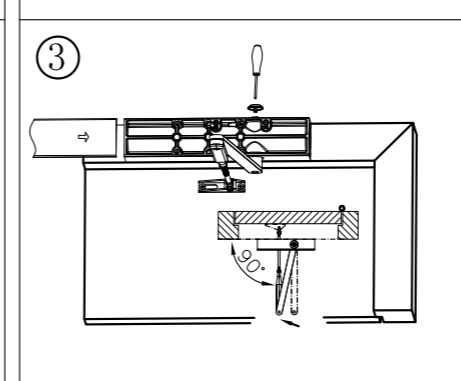
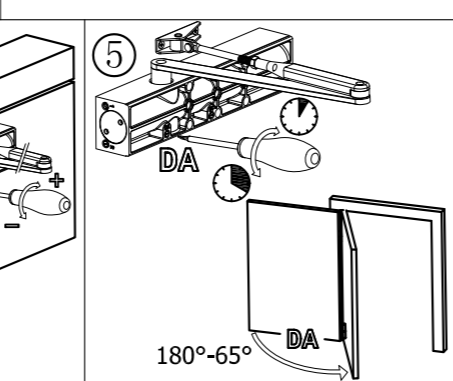
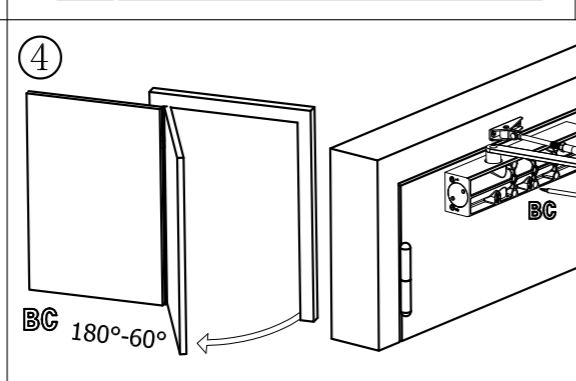
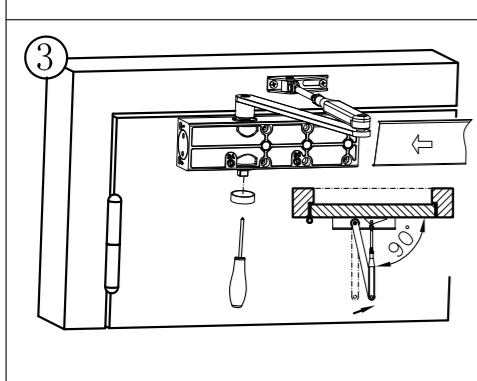
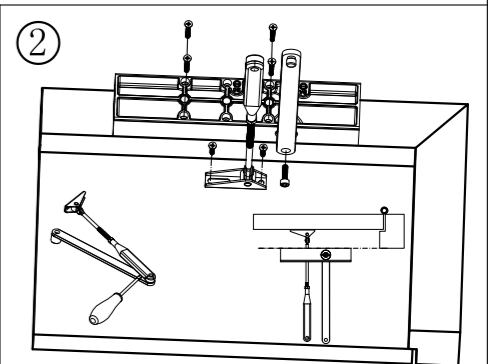
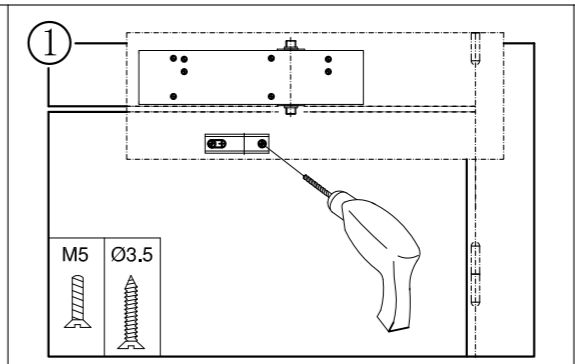
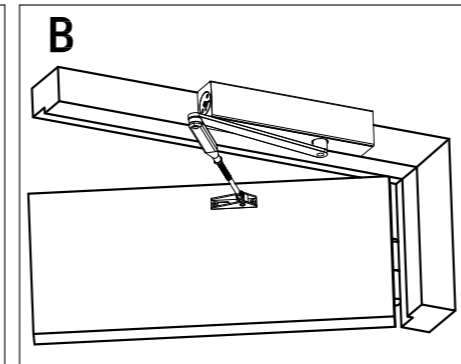
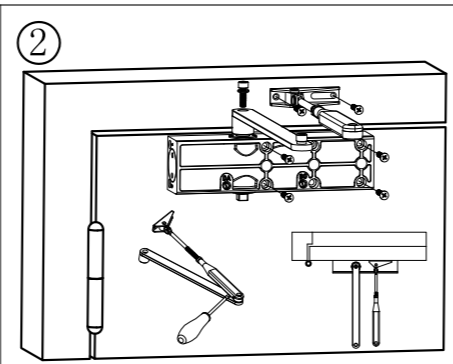
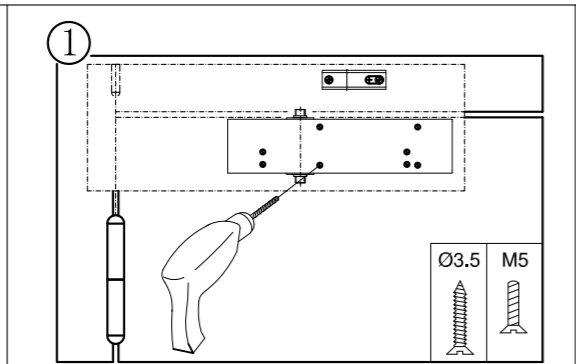
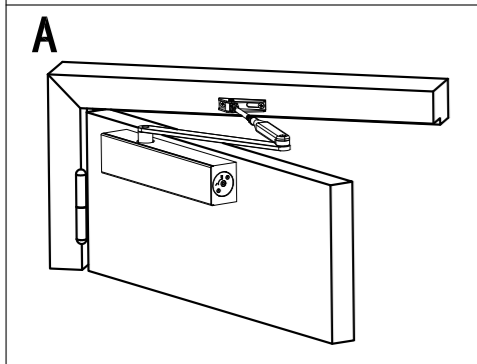
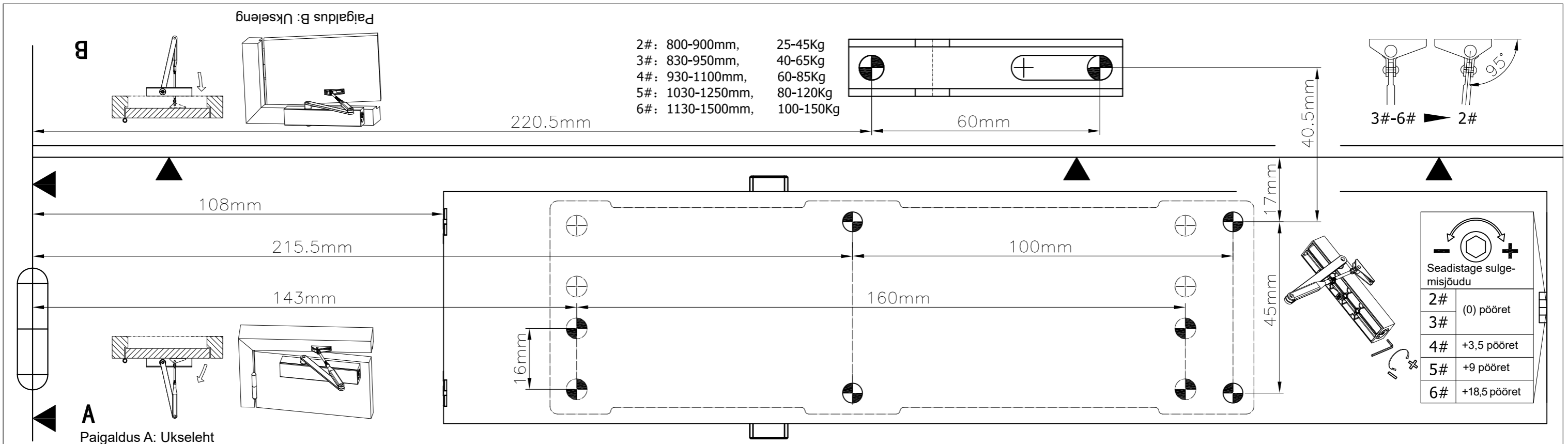

Ettevaatust

- Enne ukseulguri paigaldamist on rangelt keelatud pöörata ukseulguri nelikantpead rohkem kui 180 kraadi, vastasel juhul saab ukseulgur kahjustada.
- Ukseulguri hoova nelikantpeale paigaldamisel on rangelt keelatud sellele koputada, vastasel juhul saab ukseulgur kahjustada.
- Ukseulguri on automaatne ukse sulgemise omadus. Ukse sulgemine välise jõuga on rangelt keelatud, vastasel juhul saab ukseulgur kahjustada.
- Üks kuu pärast esmast paigaldamist ja kasutamist katsuge, kas kõikide osad kruvid on kinni.
- Suve- ja talvehooaja temperatuuride erinevuse tõttu pöörake tähelepanu sulgemiskiiruse seadistamise vajadusele.
- Kiiruse seadistamisel on rangelt keelatud keerata kiiruse seadistusventiili kere pinnast kõrgemale, vastasel juhul võib see põhjustada õlilekke.

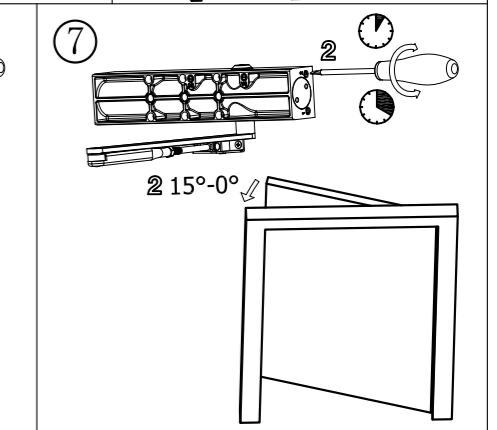
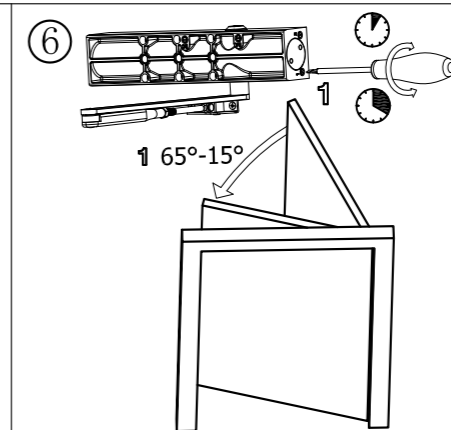

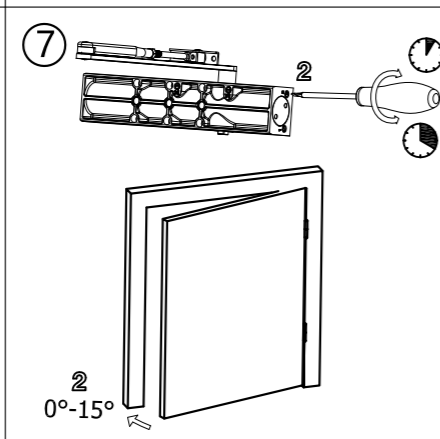
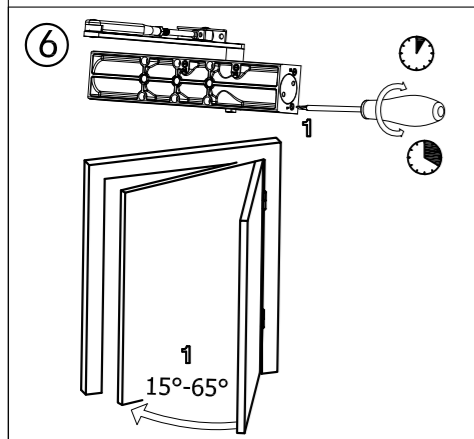
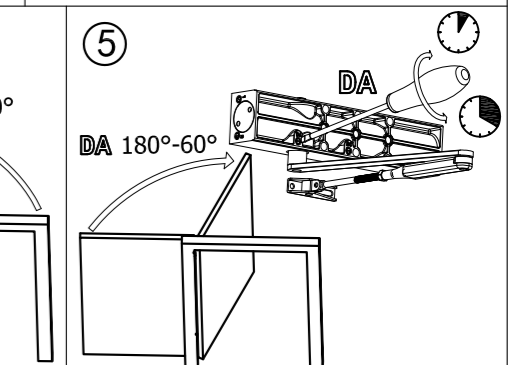
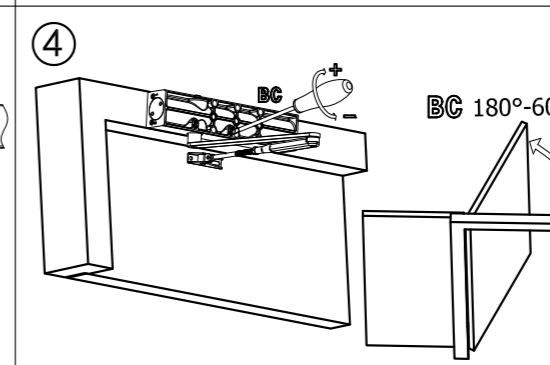
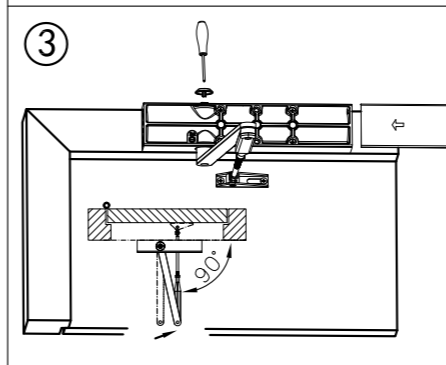
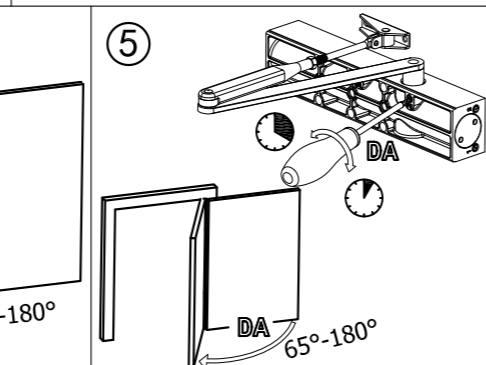
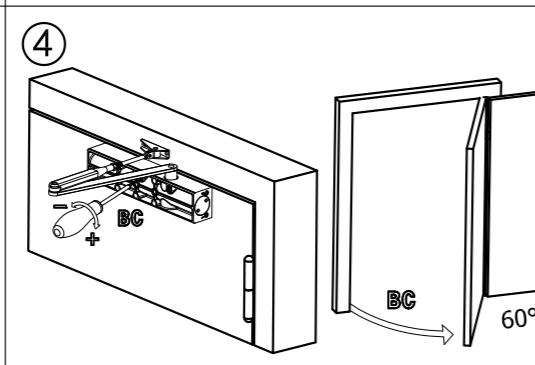
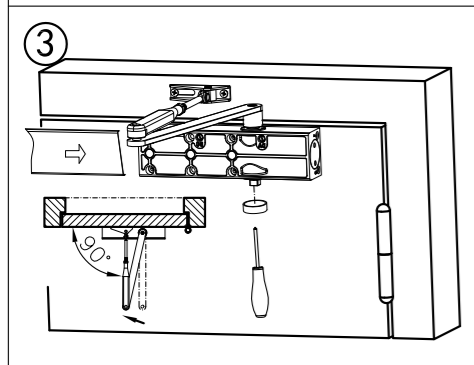
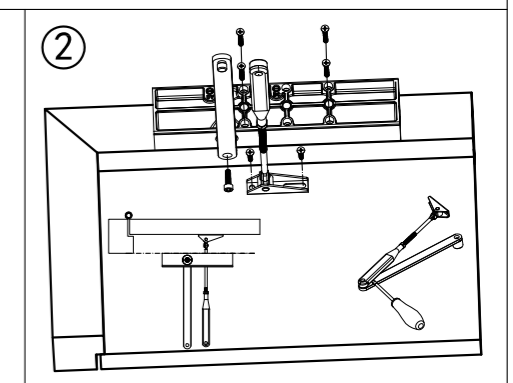
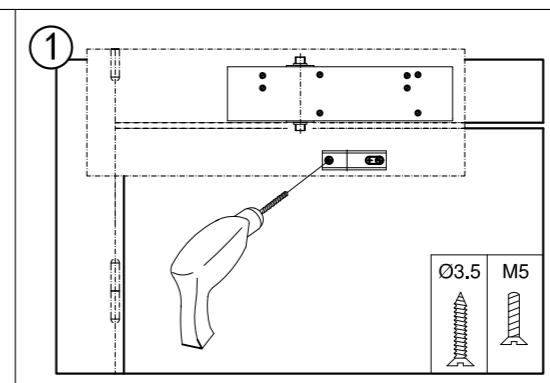
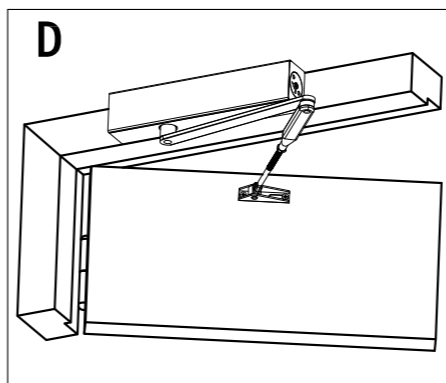
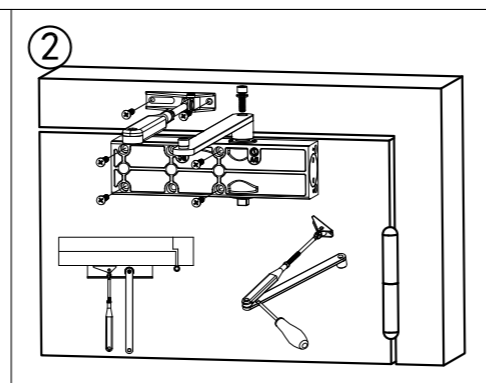
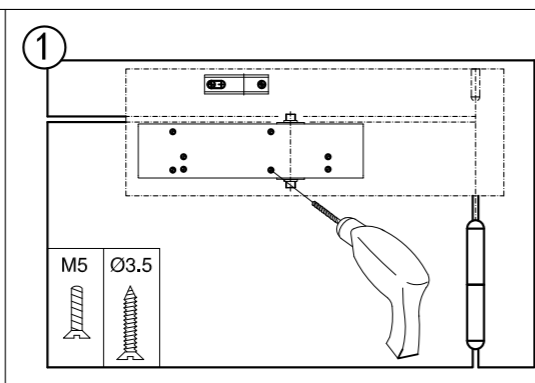
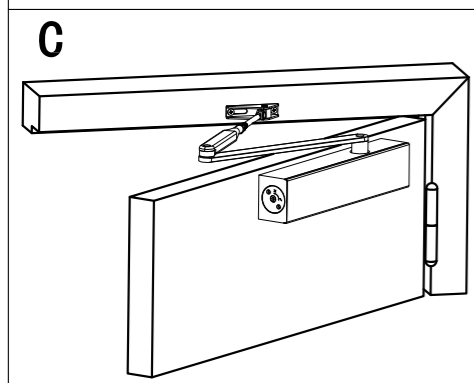
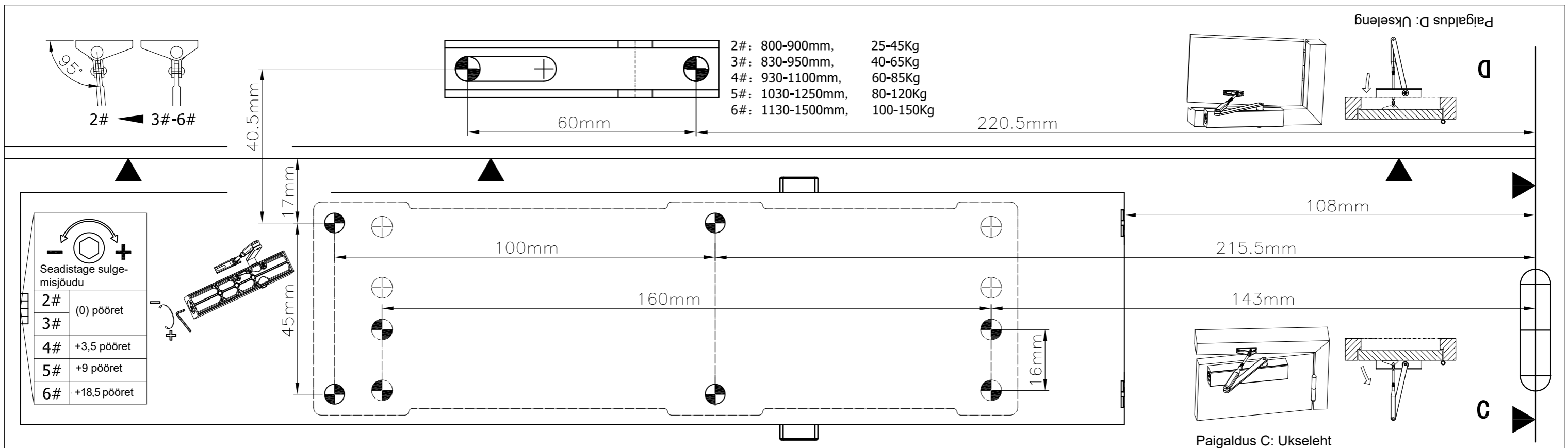

Ettevaatust

1. Enne ukse sulguri paigaldamist on rangelt keelatud pöörata ukse sulguri nelikantpead rohkem kui 180 kraadi, vastasel juhul saab ukse sulgur kahjustada.
2. Ukse sulguri hoova nelikantpeale paigaldamisel on rangelt keelatud sellele koputada, vastasel juhul saab ukse sulgur kahjustada.
3. Ukse sulguril on automaatne ukse sulgemise omadus. Ukse sulgemine välise jõuga on rangelt keelatud, vastasel juhul saab ukse sulgur kahjustada.
4. Üks kuu pärast esmast paigaldamist ja kasutamist katsuge, kas kõikide osad kruvid on kinni.
5. Suve- ja talvehooaja temperatuuride erinevuse tõttu pöörake tähelepanu sulgemiskiiruse seadistamise vajadusele.
6. Kiiruse seadistamisel on rangelt keelatud keerata kiiruse seadistusventiili kere pinnast kõrgemale, vastasel juhul võib see põhjustada õlilekke.

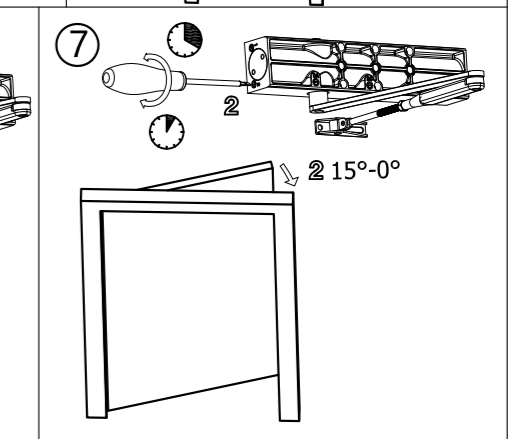
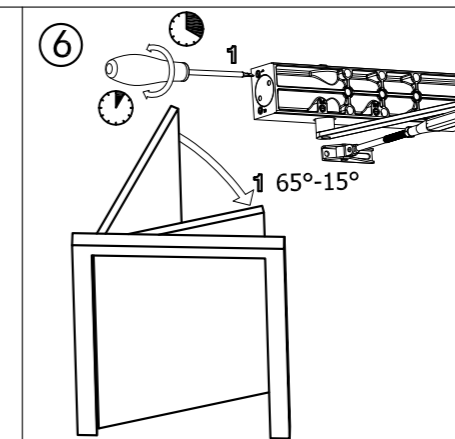

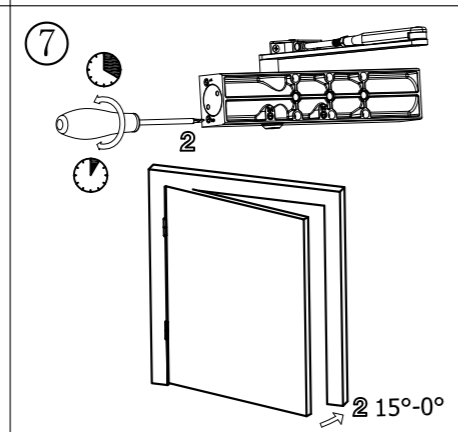
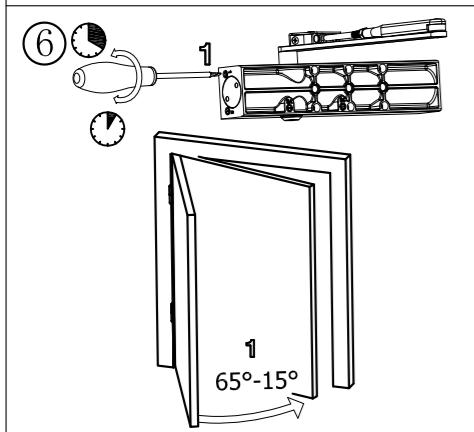
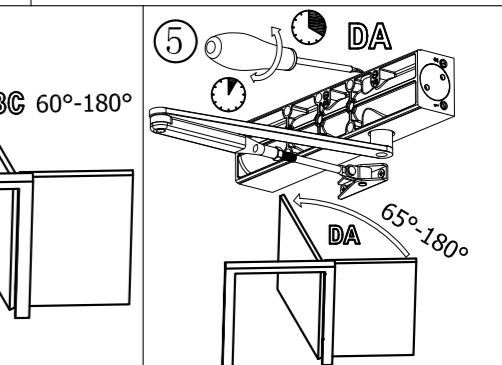
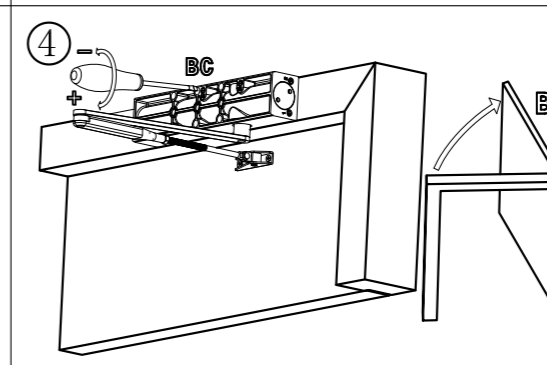
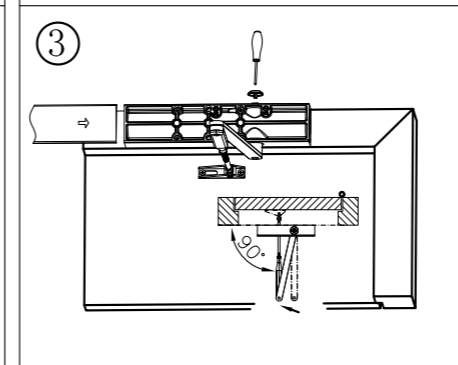
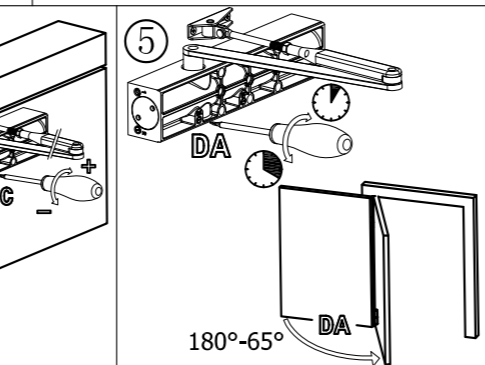
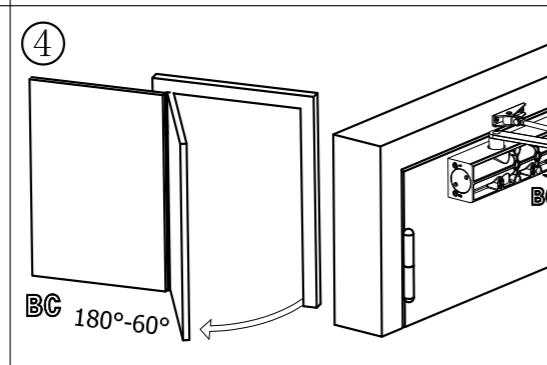
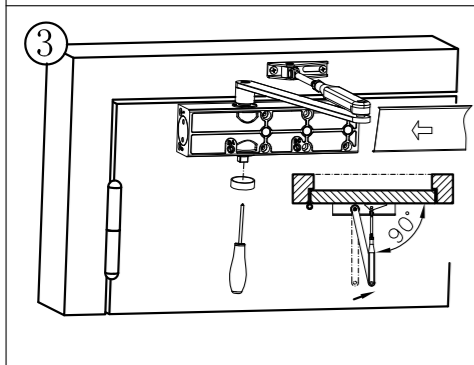
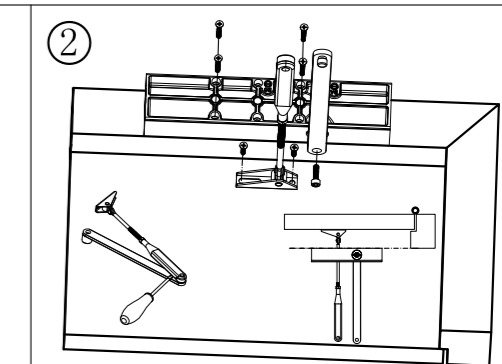
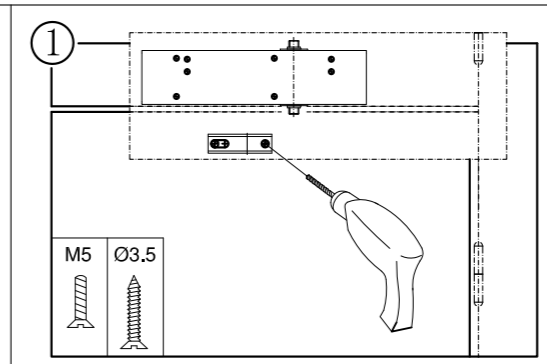
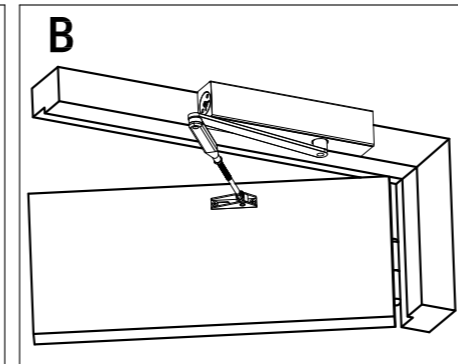
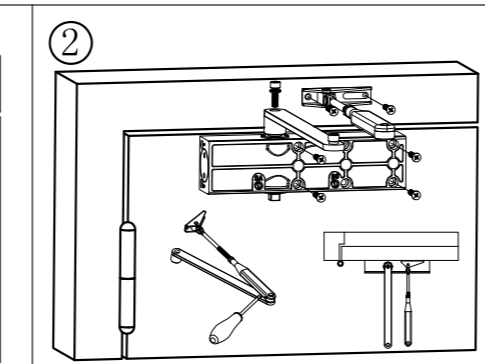
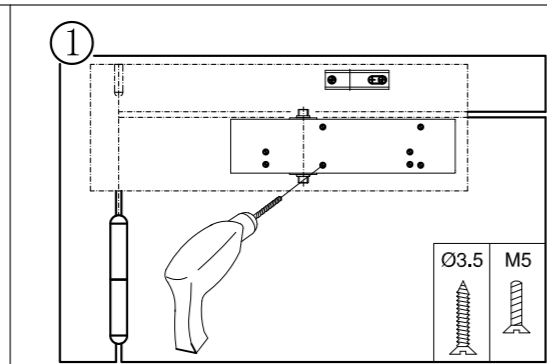
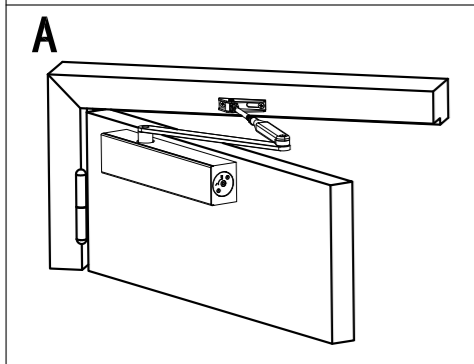
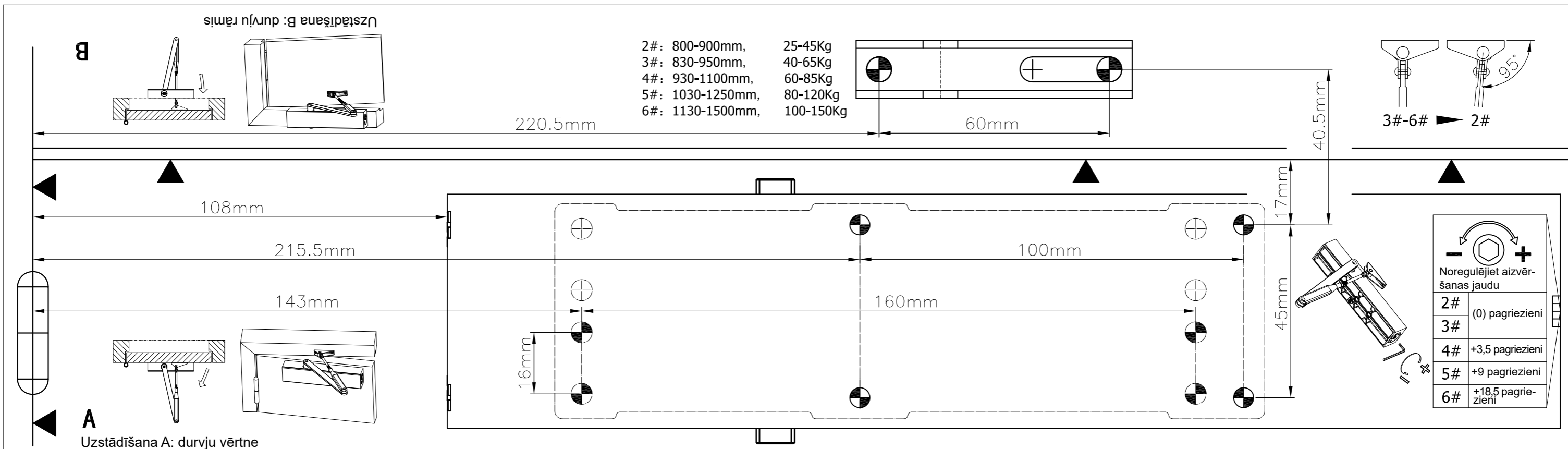

Uzmanību!

1. Pirms durvju aizvērēja uzstādīšanas ir stingri aizliegts pagriezt durvju aizvērēja bloka kvadrātveida galvu vairāk par 180 grādiem, pretējā gadījumā tiks sabojāts durvju aizvērējs.
2. Kad durvju aizvērēja savienošanas svira ir uzstādīta uz kvadrātveida galvas, stingri aizliegts pa to spēcīgi klauvēt, pretējā gadījumā tiks sabojāts durvju aizvērējs.
3. Durvju aizvērējam ir automātiska durvju aizvēršanas funkcija. Ir stingri aizliegts piespiest durvis aizvērt ar ārēju spēku, pretējā gadījumā tiks sabojāts durvju aizvērējs.
4. Pēc viena mēneša sākotnējās uzstādīšanas un lietošanas pārbaudiet, vai katras daļas skrūves nav vaļīgas.
5. Tā kā vasaras un ziemas sezonās temperatūras atšķiras, lūdzu, pievērsiet uzmanību aizvēršanas ātruma regulēšanai.
6. Regulējot ātrumu, ir stingri aizliegts pagriezt ātruma regulēšanas vārsta skrūvi augstāk par korpusa virsmu, pretējā gadījumā tas izraisīs eļļas noplūdi.

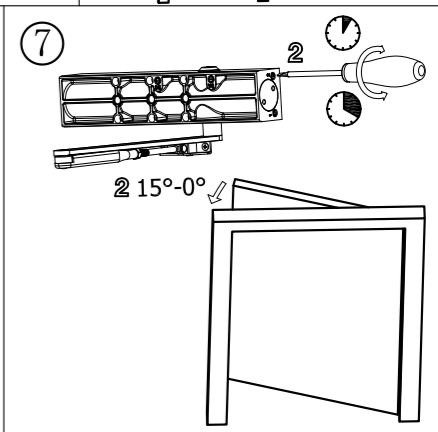
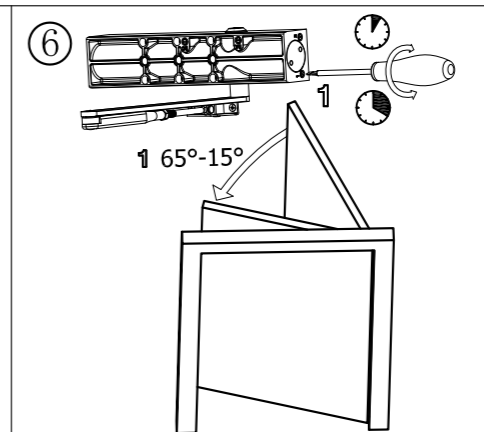

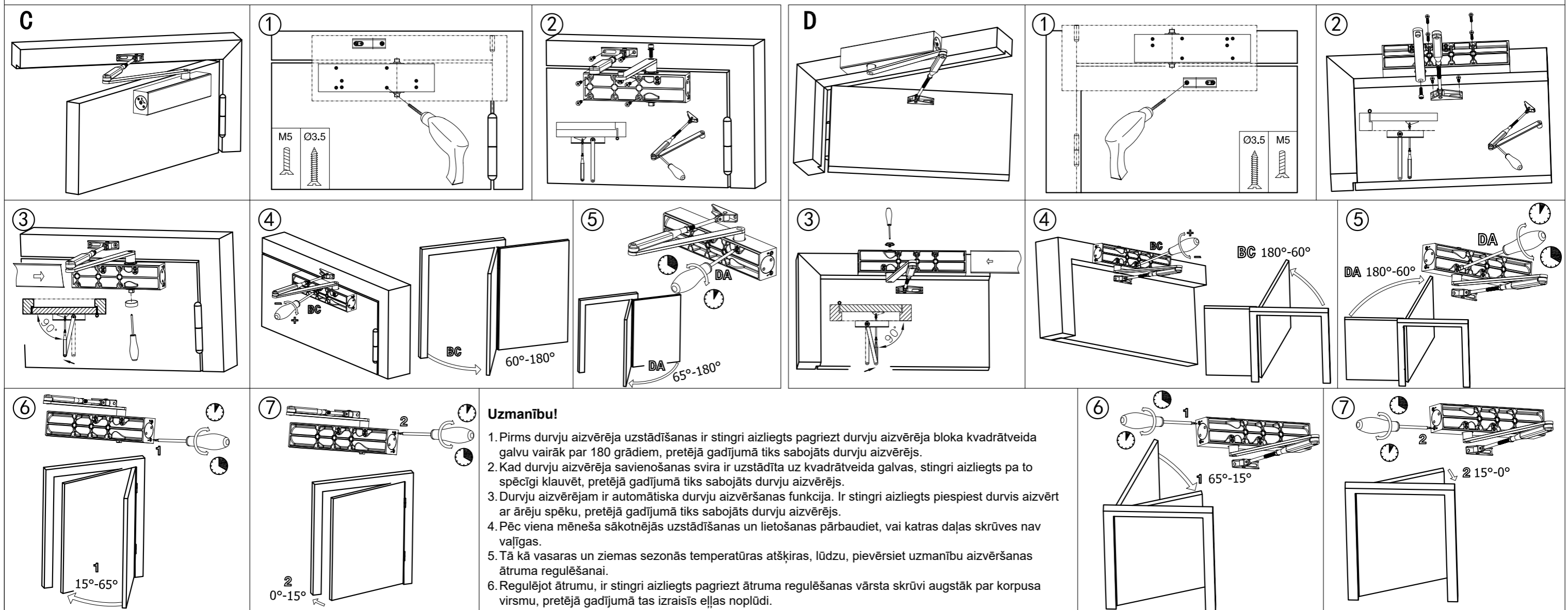
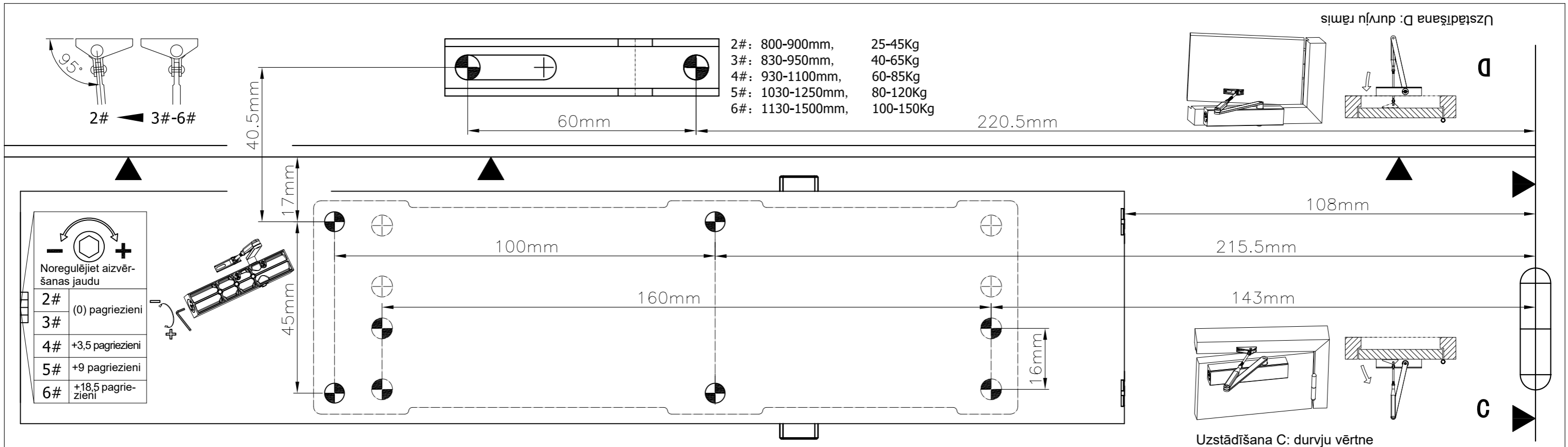

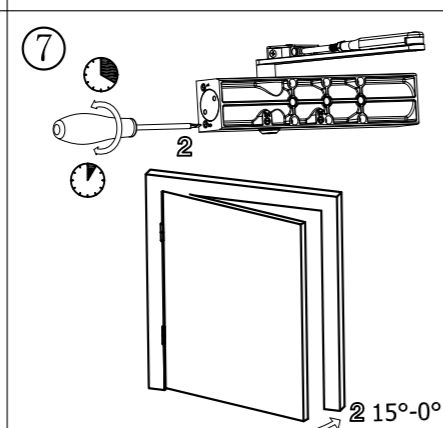
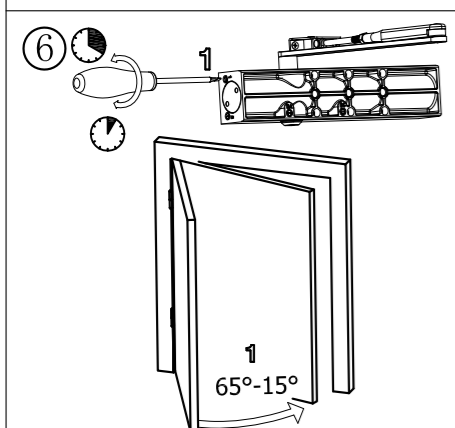
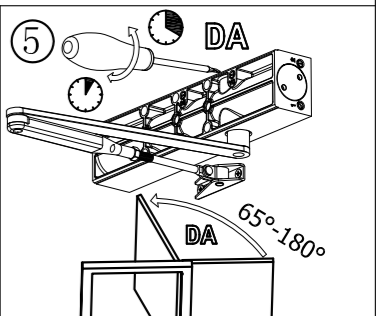
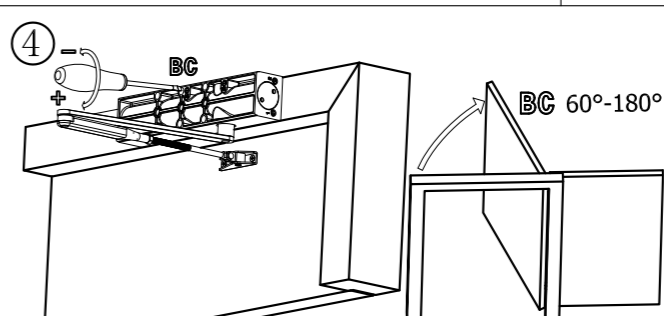
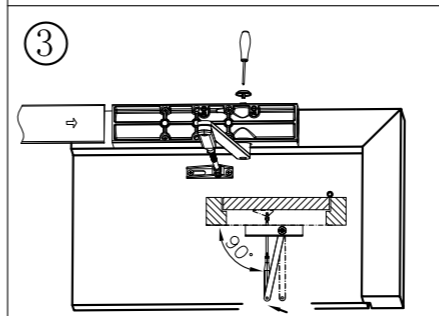
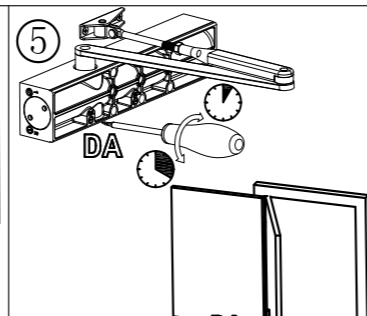
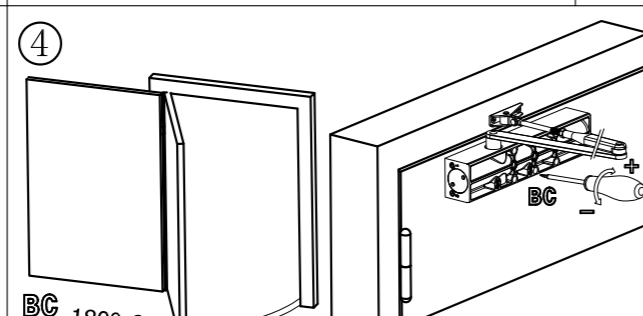
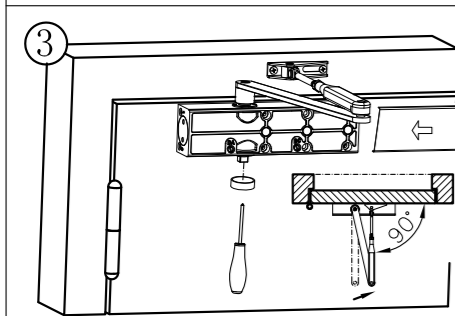
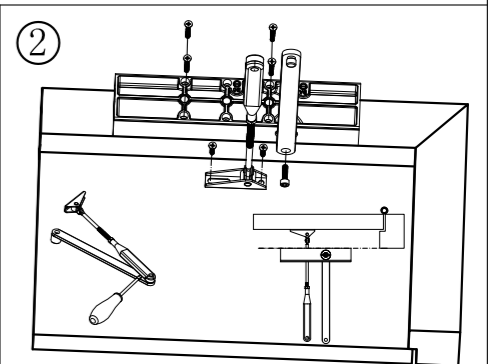
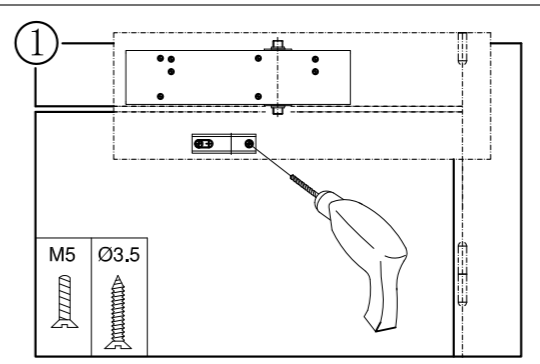
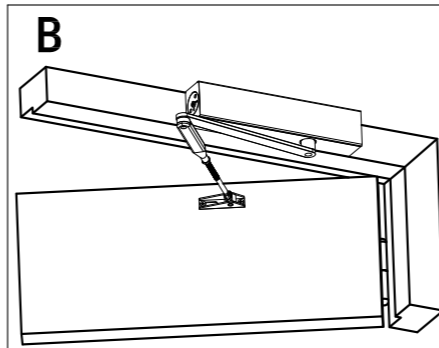
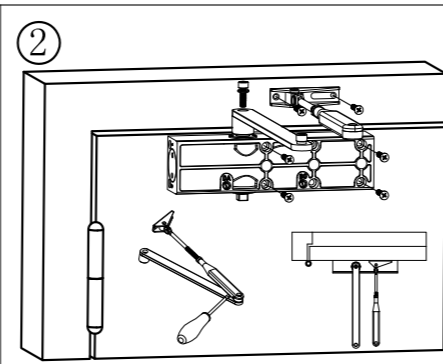
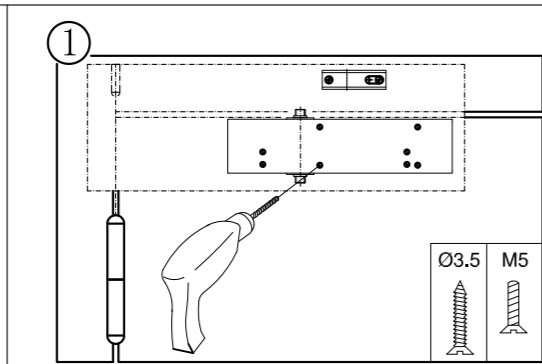
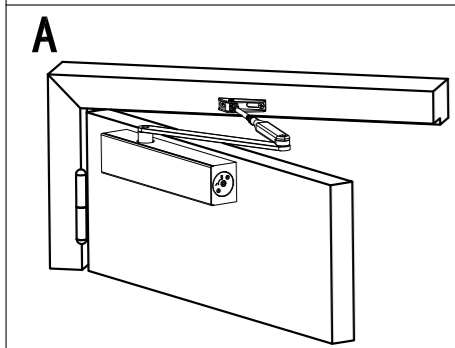
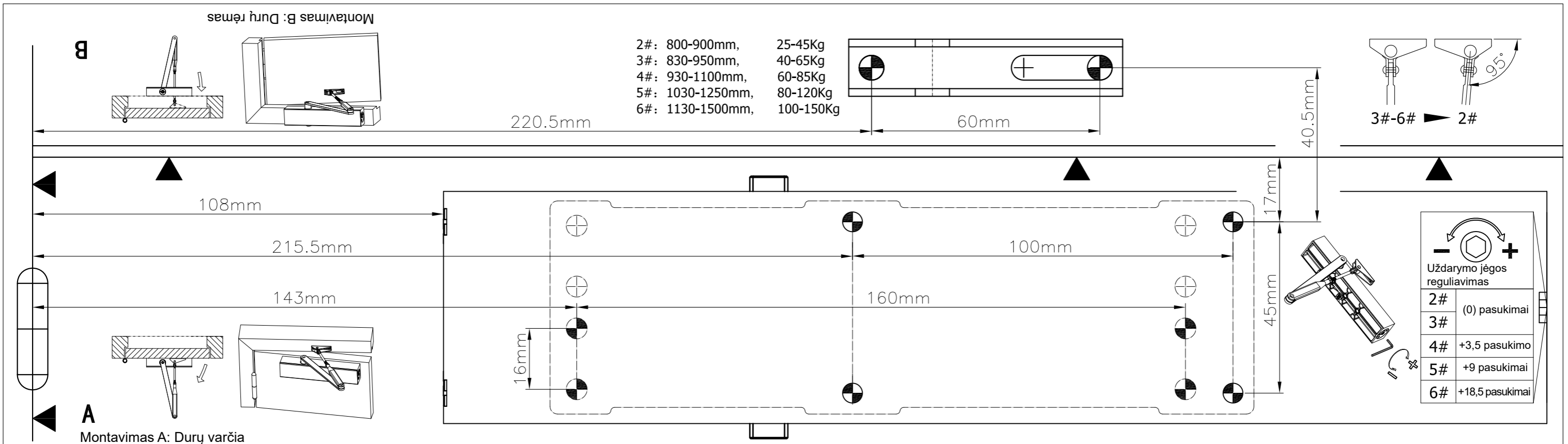

Ispėjimai

- Griežtai draudžiama prieš montuojant durų uždarymo įtaisą pasukti jo kvadratinę galvutę daugiau nei 180 laipsnių kampu. Nesilaikant šio nurodymo, durų uždarymo įtaisas gali būti sugadintas.
- Pritvirtinus durų uždarymo įtaiso jungiamąjį svirtį ant kvadratinės galvutės, griežtai draudžiama ją stipriai trankyti. Nesilaikant šio nurodymo, durų uždarymo įtaisas gali būti sugadintas.
- Durų uždarymo įtaisas turi automatinio durų uždarymo funkciją. Griežtai draudžiama uždaryti duris naudojant išorinę jėgą. Nesilaikant šio nurodymo, durų uždarymo įtaisas gali būti sugadintas.
- Praėjus mėnesiui nuo pirmojo montavimo ir naudojimo, patikrinkite, ar gerai priveržti visų dalių varžtai.
- Atkreipkite dėmesį, kad dėl vasaros ir žiemos temperatūros skirtumų gali tekti pareguliuoti uždarymo greitį.
- Reguliuojant greitį griežtai draudžiama greičio reguliavimo vožtuvą sukėti virš korpuso paviršiaus. Nesilaikant šio nurodymo, gali įvykti alyvos nuotėkis.

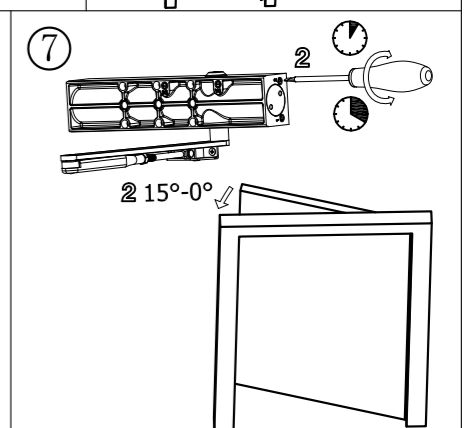
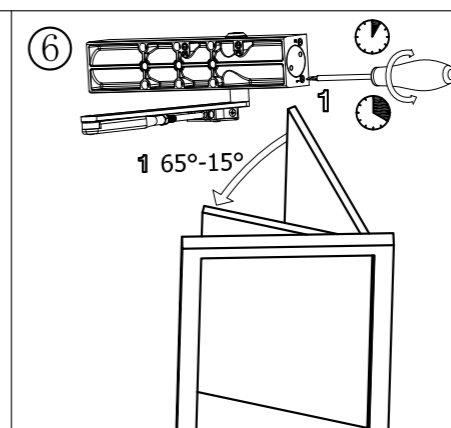

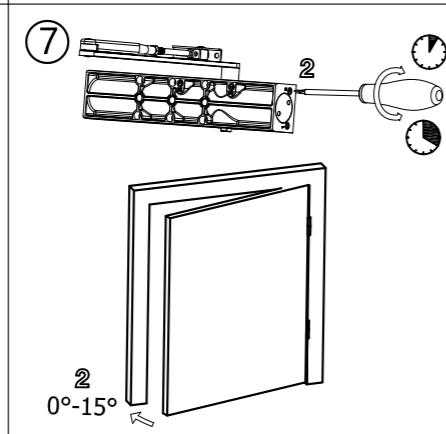
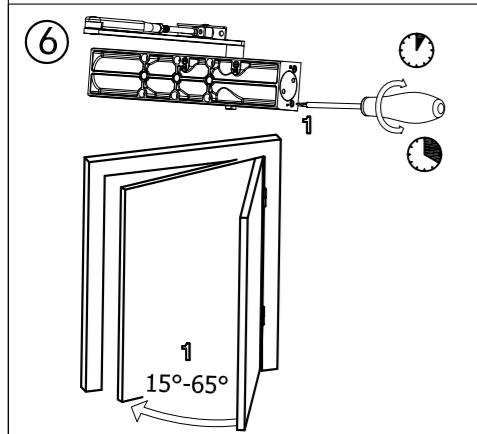
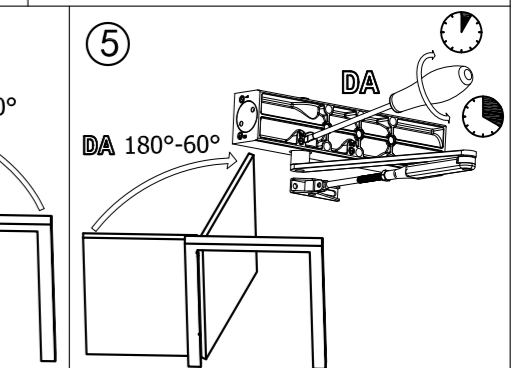
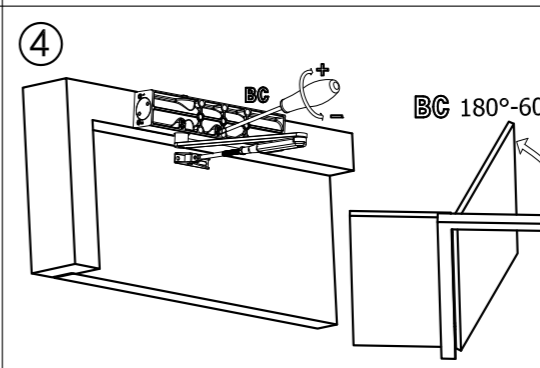
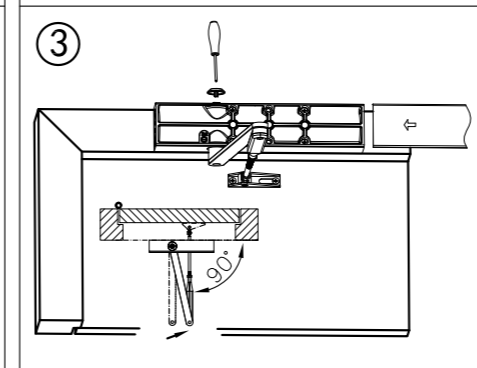
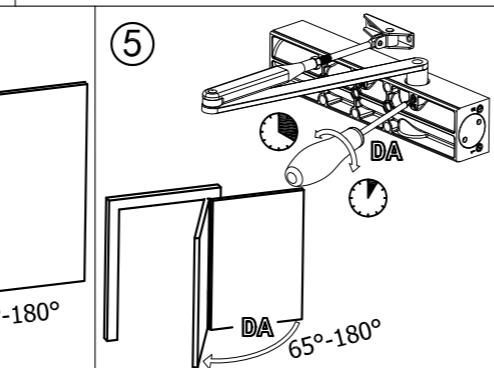
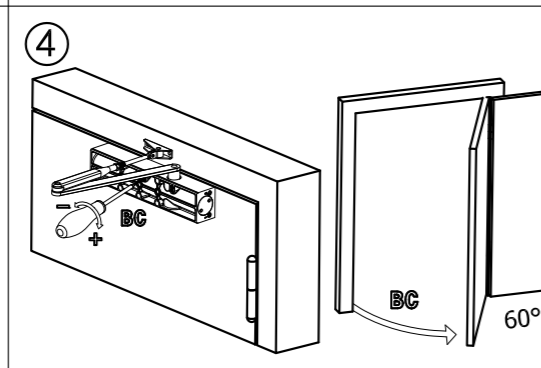
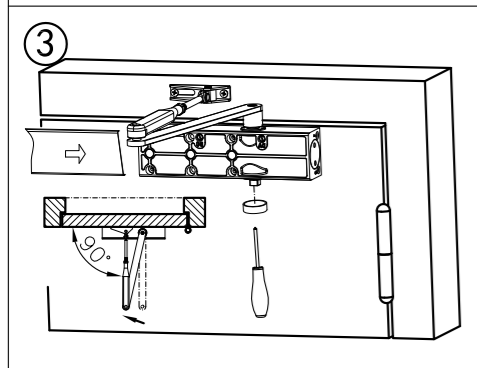
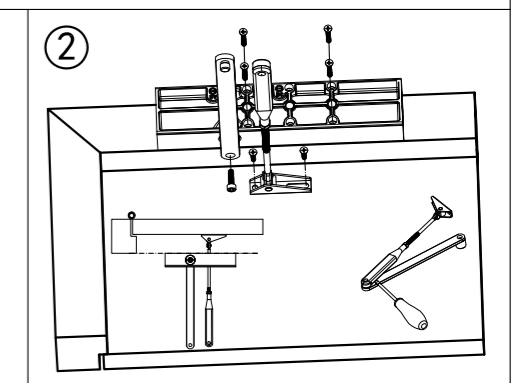
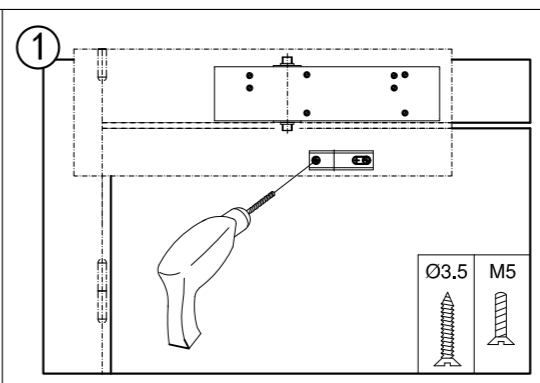
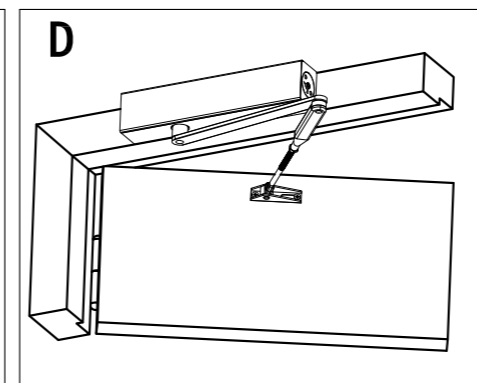
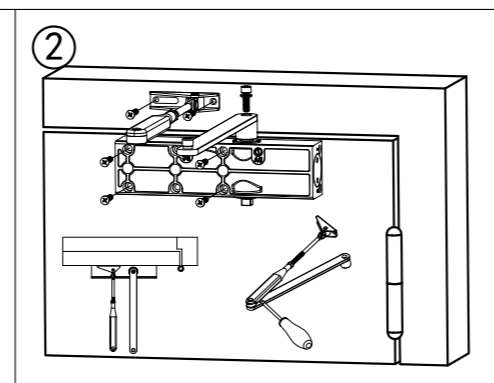
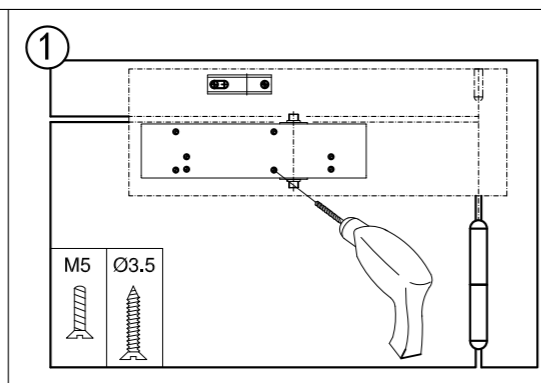
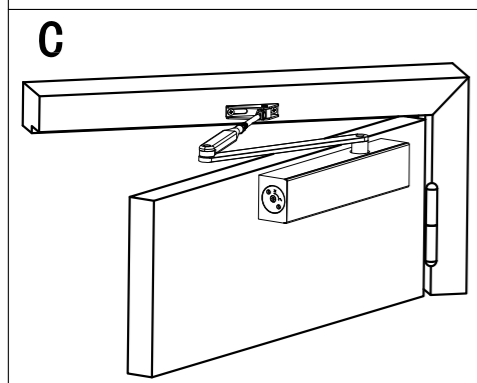
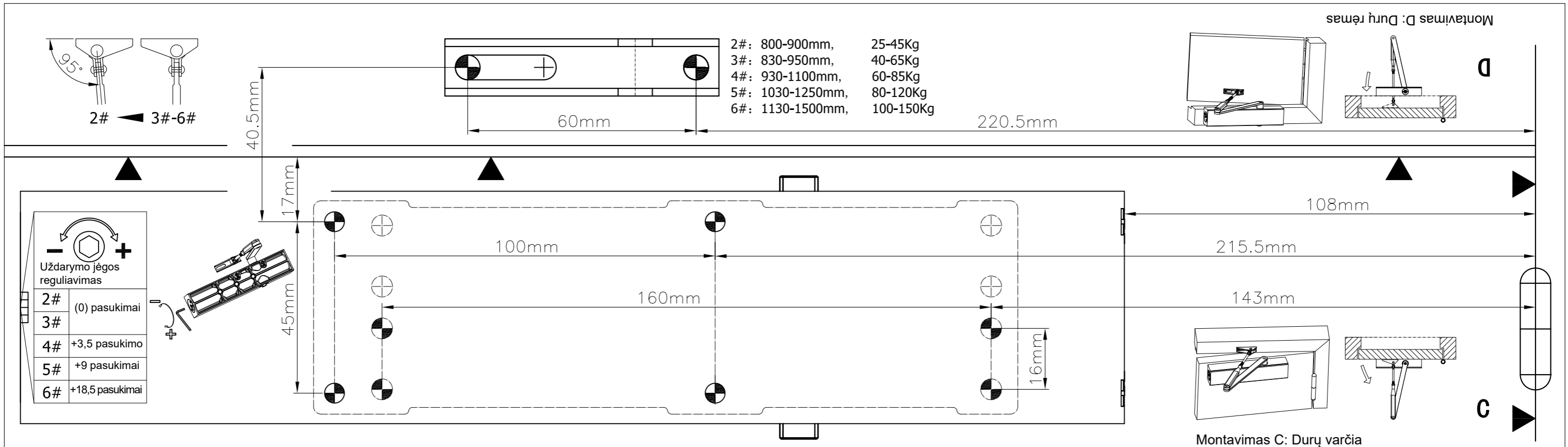

Įspėjimai

- Griežtai draudžiama prieš montuojant durų uždarymo įtaisą pasukti jo kvadratinę galvutę daugiau nei 180 laipsnių kampu. Nesilaikant šio nurodymo, durų uždarymo įtaisas gali būti sugadintas.
- Pritvirtinus durų uždarymo įtaiso jungiamąją svirtį ant kvadratinės galvutės, griežtai draudžiama ją stipriai trankyti. Nesilaikant šio nurodymo, durų uždarymo įtaisas gali būti sugadintas.
- Durų uždarymo įtaisas turi automatinio durų uždarymo funkciją. Griežtai draudžiama uždaryti duris naudojant išorinę jėgą. Nesilaikant šio nurodymo, durų uždarymo įtaisas gali būti sugadintas.
- Praėjus mėnesiui nuo pirmojo montavimo ir naudojimo, patikrinkite, ar gerai priveržti visų dalių varžtai.
- Atkreipkite dėmesį, kad dėl vasaros ir žiemos temperatūros skirtumų gali tekti pareguliuoti uždarymo greitį.
- Reguliuojant greitį griežtai draudžiama greičio reguliavimo vožtuvo varžtą sukuti virš korpuso paviršiaus. Nesilaikant šio nurodymo, gali įvykti alyvos nuotėkis.

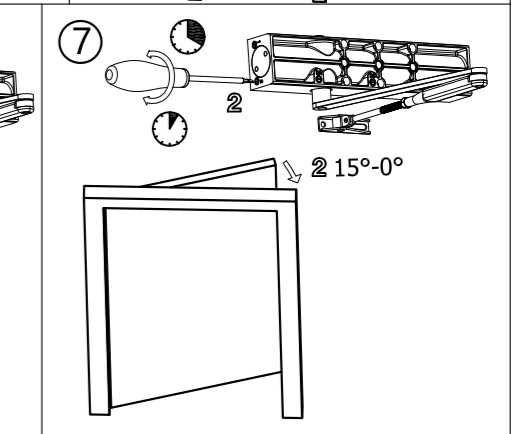
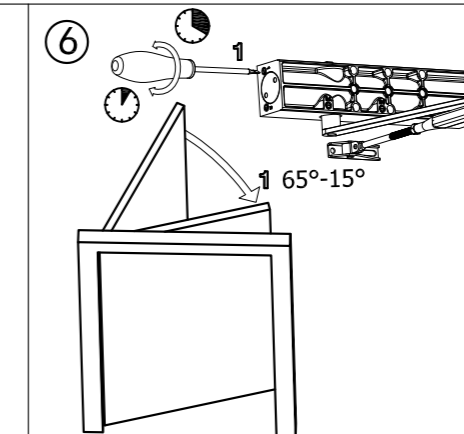



Pisla Oy
Teollisuustie 6-8,
44500 Viitasaari FINLAND
+358 10 843 210
www.pisla.fi